

Diaphragm Actuators

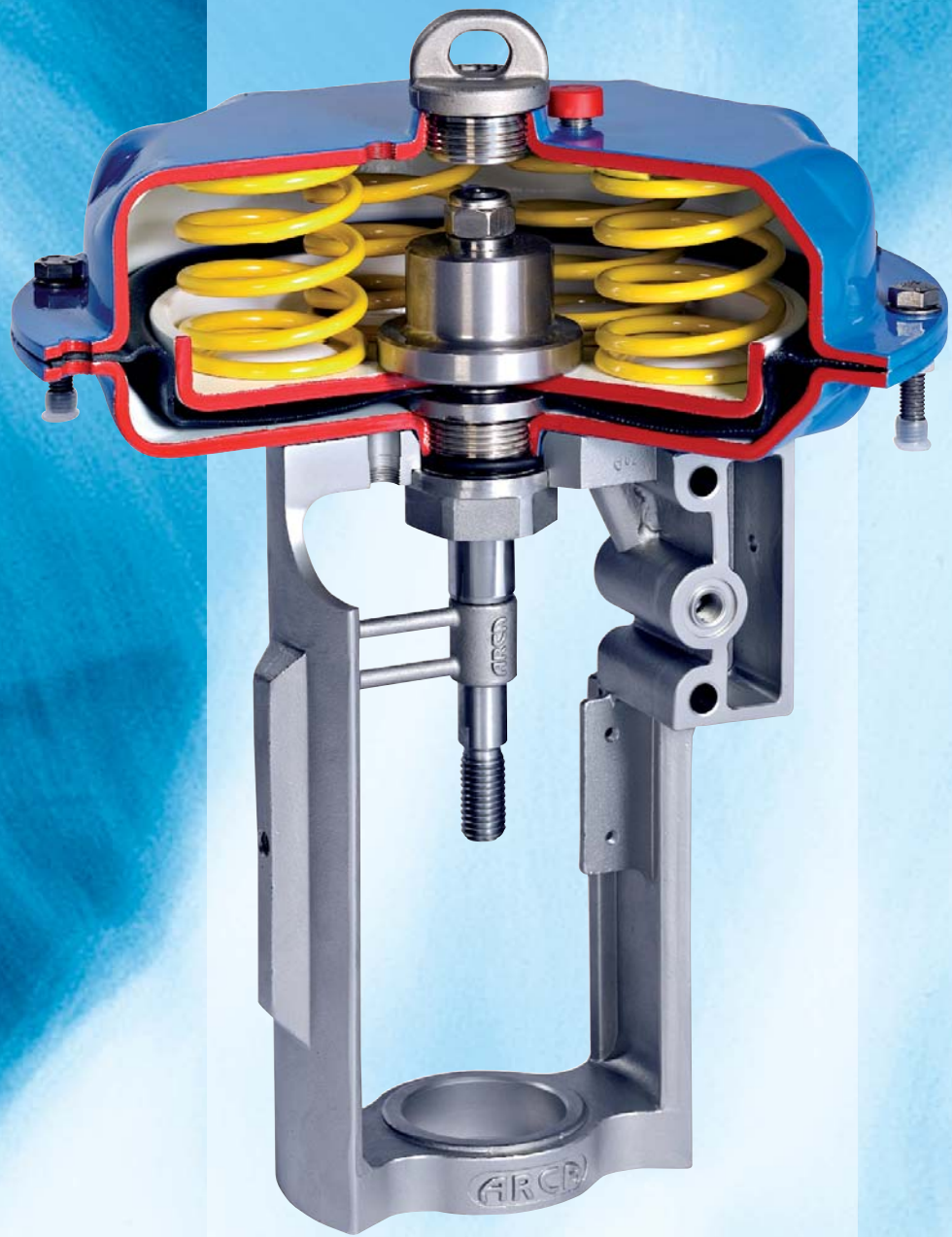

ARCA
VALVES
*quality engineered
control valves*

Diaphragm Actuators

Favorable Variety

Whether rotary or linear – with pneumatic, electric, and hydraulic valve actuators from ARCA Regler GmbH, you always have the right solution at hand. ARCA's comprehensive product portfolio offers a choice of valve actuators ranging from low to very high actuating forces and torques. If requested, we can also develop and manufacture actuators that are optimized for safety-oriented applications or have extremely short actuating times. Low lifecycle costs are a feature shared by all our actuators.

Pneumatic Diaphragm Actuators

The simple design of our pneumatic diaphragm actuators with a robust rolling diaphragm makes them universal in application while ensuring hysteresis-free control across the entire actuating range. These pneumatic valve actuators can be opened or closed using spring force or control air – an option that is field-reversible, making the devices very versatile and providing security for your investments. The integrated compression springs ensure that the pneumatic control actuator always adopts a defined fail position. This is accomplished with very short actuating times meaning that alongside their control tasks, ARCA diaphragm actuators also play a key role in safeguarding the plant. Explosion protection is not an issue when configuring pneumatic diaphragm actuators. If required, a manual emergency override can be adapted.

Electric Actuators

Actuating and control forces are transferred to the valve using geared motors to ensure that the forces are always available on demand. Suitable gear reductions guarantee that even extremely high actuating forces are transferred safely and reliably. Electric actuators are normally equipped with a handwheel. End positions are adjusted via configurable torque or travel limit switches. Explosion protection and an emergency control function can be realized as an option. A standardized interface allows the actuators to be used for all common applications.

Hydraulic Actuators

These are characterized by their high actuating forces and speeds. Because of the double piping for the inflow and outflow of media, hydraulic actuators are only specified for high-end technical applications. In conjunction with leading manufacturers, we can offer you the correct make to suit your specific requirements.

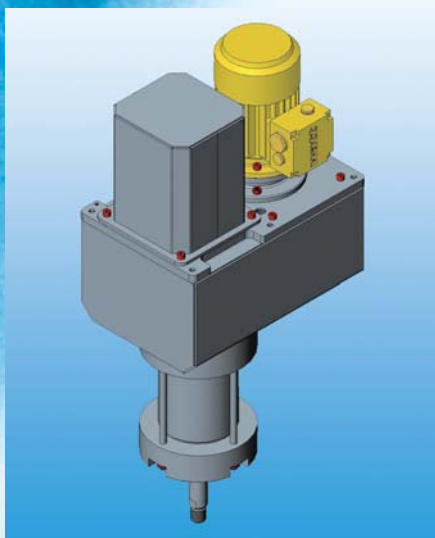
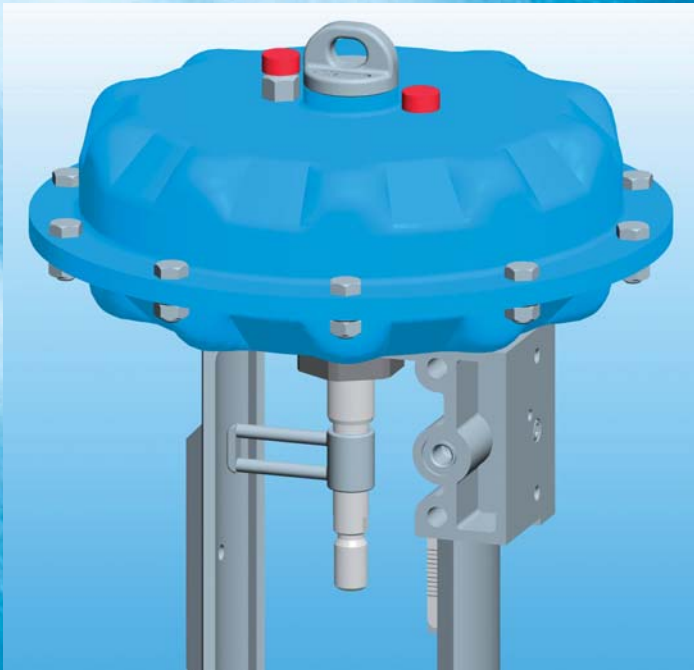

Pneumatic Multi-Spring Actuator Type 812

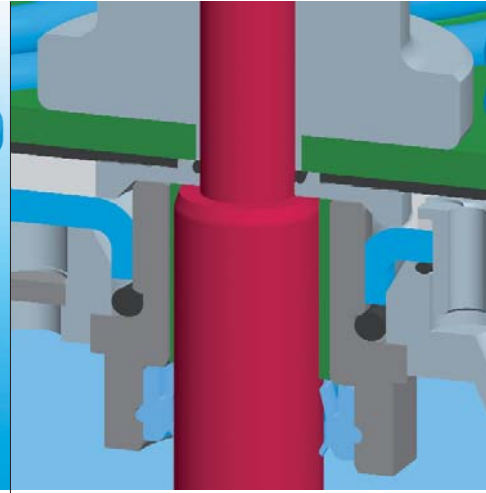
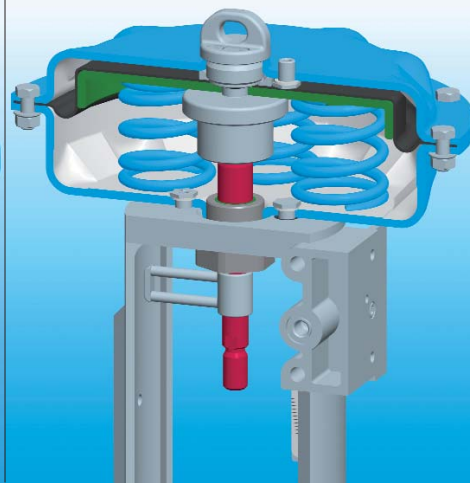
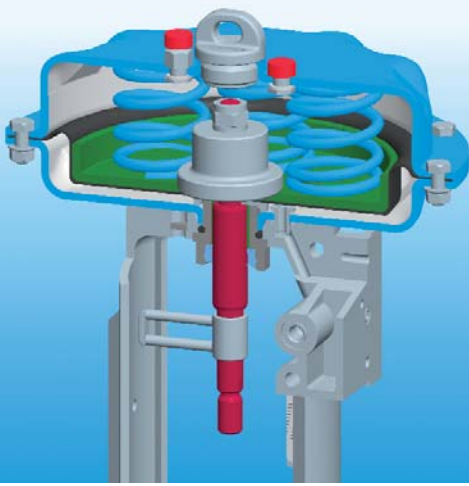

The Benefits of Our Standard Version

This pneumatic actuator is identical as regards the «air to open» (Fig. 1) and «air to close» (Fig. 2) functions, which allows you to reverse the actuator on site, as installed, with minimal manual intervention and without opening the actuator housing. This design prevents internal parts from being lost and the powder-coated actuator shells are not damaged at the contact points with the bolts and nuts. With this the rolling diaphragm, which has proven itself thousands of times over, is also protected from damage. Special plugs for aerating and bleeding ensure the highest possible protection against spray water and other environmental influences. The multi-spring design enables very compact dimensions. A stainless steel variant is available for demanding process conditions as encountered in the food industry.

Special Protection for the Actuator Stem

The stem lead-through is designed to be maintenance-free, even when used in harsh, dusty environments. Dirt particles are reliably deflected upstream of the guide and sealing element to prevent damage from occurring in these areas near the super finished and finish-rolled stems for ultra-high operating reliability.

Universal Diaphragm Actuator Type 811

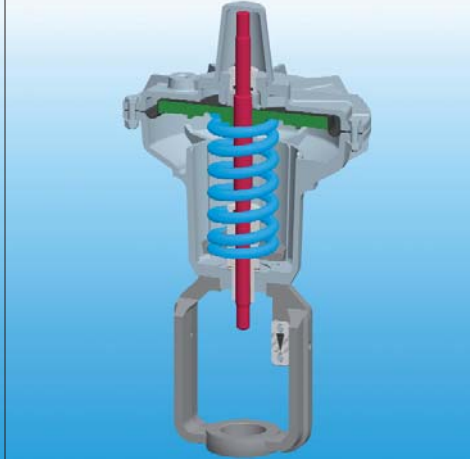
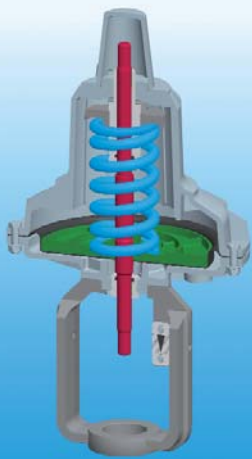

Double-Acting Piston Actuator

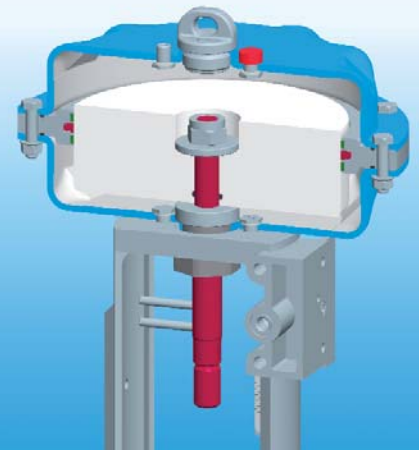

The universal diaphragm actuator, type UMA 811, is a product line comprising four sizes of actuator. The stem features a twin design and both interfaces for adapting to the valve are identical to facilitate toggling between the two directions. Instrumentation can be added by way of standardized NAMUR ribbing. An emergency override facility is available as an option.

A tensioning screw as commonly used in pneumatic regulation is used to adapt the spring preload to the actuating forces required with pinpoint accuracy. This, in conjunction with different-sized centric springs, enables a very broad range of actuating forces to be optimally set. High accuracy is achieved by making adjustments at the outward-facing side, in the installed state, with further fine-tuning possible during operation.

Internal development of the double-acting piston actuator, type 812.MFi-DWK, allows us to accommodate the special requirements associated with large driving forces in both directions as well as very short actuating times for extremely high switching frequency. The basis for this is proven control actuator technology and the combination of compact design, long service life, and high availability. The interfaces have also been retained so that the integrated positioner assembly can be used with the integrated air ducting as has the valve interface, allowing accessories to be retrofitted at any time.

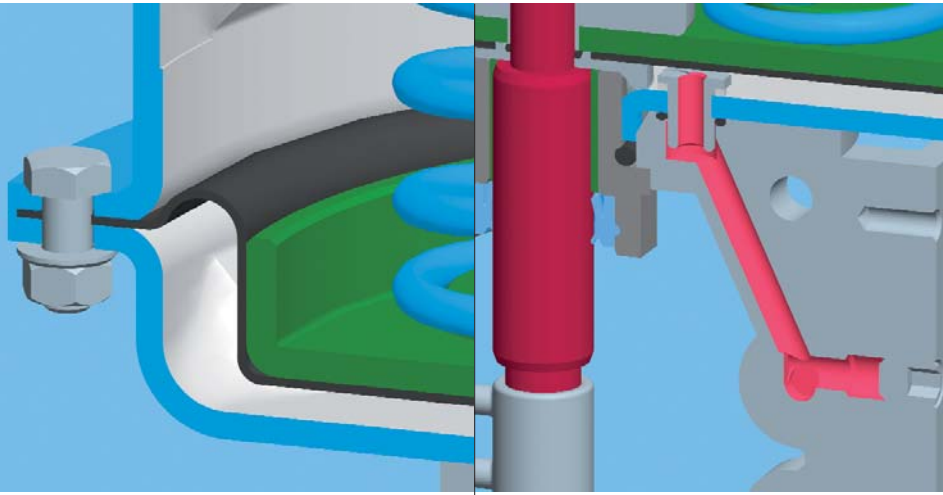

Diaphragm and Diaphragm Clamping with Enclosure

The rolling diaphragm used by ARCA is maintenance-free thanks to a super finished housing and diaphragm plate. The diaphragm clamping system has proven to be crucial in terms of service life, however. Our diaphragm clamping system with force bypass further extends the service life of the diaphragm significantly. The force bypass design prevents the maximum permissible surface pressure from being exceeded which, in turn, prevents the diaphragm from being installed incorrectly as is otherwise evidenced in seepage at the actuator shells.

Integrated Air Ducting

ARCA is known for its integrated air ducting and backlash-free stroke feedback. This makes it possible to easily integrate accessories such as positioners or solenoid valves with the actuator. The actuating pressure can thus be channeled from the positioner through the actuator yoke to the actuator without the need for additional piping. Elaborate, vulnerable external piping is therefore not required, which rules out leakage and provides for very high operating reliability and exceptional serviceability.

Manual Emergency Override (Option)

The pneumatic diaphragm actuator can be easily equipped or retrofitted with an emergency override so that the actuator stem can be moved to the desired position against the spring force. The enclosed design meets all common safety requirements.

Diaphragm Actuator MA

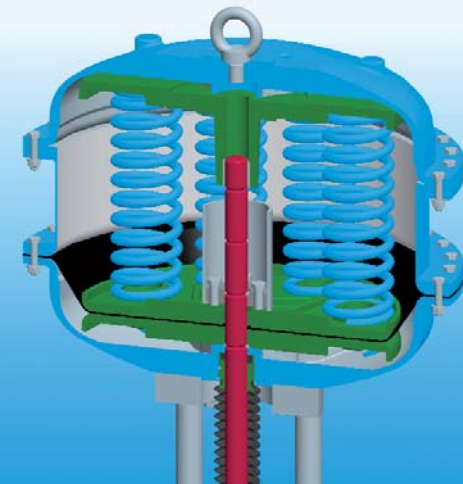

This line not only includes a single-acting model that «opens» or «closes» with air pressure increase, but a double-acting variant as well, whereby air pressure is effective in both directions onto the same double side coated diaphragm. The latter can thus be used for control and on/off applications. Instrument air is a common control medium. Clean water can also be used, however, as arranged. The housing shells are made from coated sheet steel, coated cast shells, or stainless steel. Adjustable limiters and emergency overrides are optional.

ARCAtorque 840 Rotary Actuator

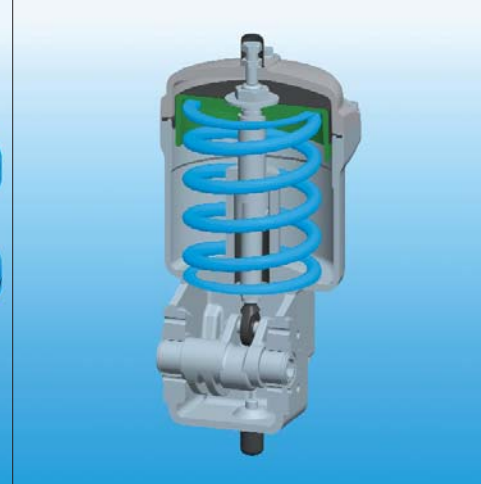

The ARCAtorque 840 targets rotary actuators designed quarter-turn movements. Four sizes are available, each of which has a double-sided connecting flange compliant with DIN/ISO requirements. The «spring to open» and «spring to close» safety functions are easy to realize with this rotary actuator. Instrumentation can be added using the same DIN/ISO connection flange.

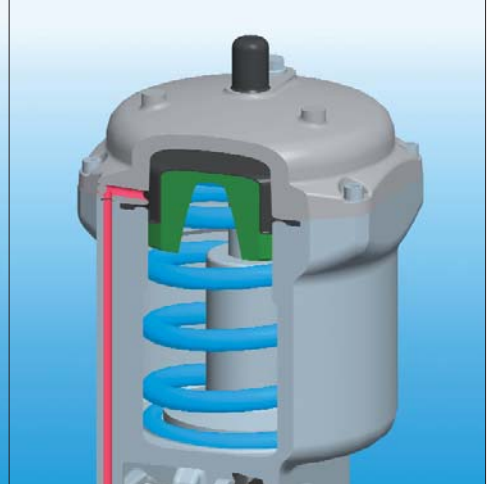

The ARCA-specific diaphragm enclosure and integrated air ducting have been integrated as a design feature. Characteristic for this pneumatic rotary actuator is the rolling diaphragm, which operates very uniformly with hysteresis-free torque output throughout the entire range. An emergency override can also be ordered or retrofitted.

Ultra-High-Precision Regulation

The pneumatically activated multi-spring diaphragm actuator Series 812 can perform key control tasks in almost all industrial areas. Not only have all current guidelines on occupational safety been considered; ARCA has also focused on environmental compatibility, durability, and impact on human health.

The unique possibility of installing the positioner with integrated air ducting and optional spring chamber purge means that your plant never needs to be maintained. Instrument air is used to operate the actuator and subsequently fill its spring chamber. This protects your control actuator from aggressive and corrosive ambient or sea air and allows us to offer actuators with above-average durability while keeping costs as low as possible.

Diaphragm Actuators

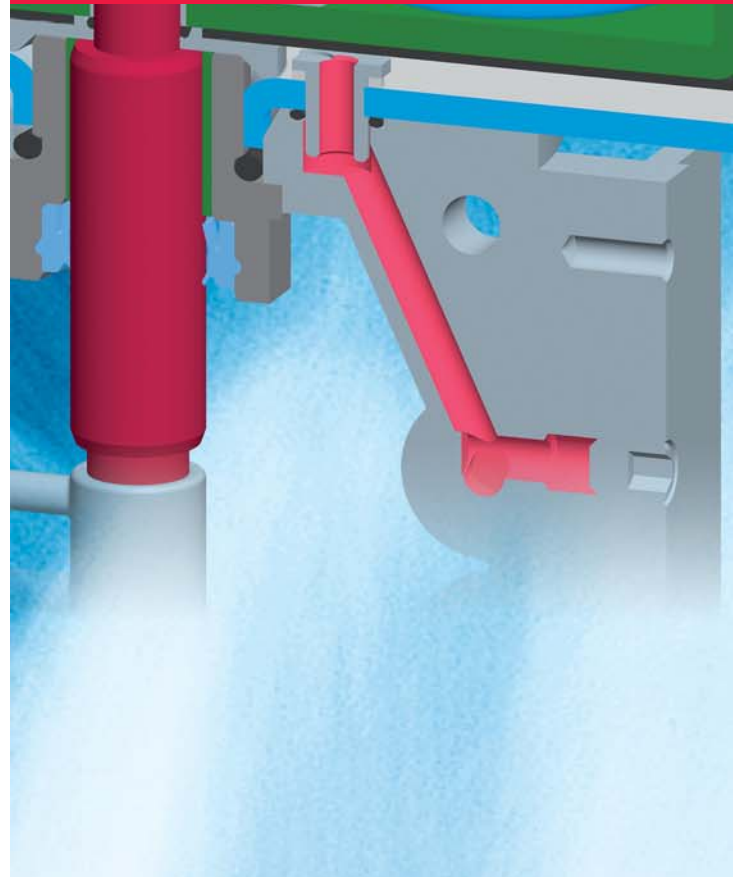

Our innovations

- 1 Reliable rolling diaphragm
- 2 Reversible actuator
- 3 Integrated air supply
- 4 Compact design
- 5 Low dead volume
- 6 Special ventilation system
- 7 Extensive choice of materials

How you benefit

- ✓ High level of availability
- ✓ Broad range of actuating force
- ✓ Short actuating times
- ✓ No hysteresis
- ✓ Easy to maintain
- ✓ One version for several applications
- ✓ Ultra-high operational reliability
- ✓ Compact design
- ✓ Clear, easy-to-read instrumentation
- ✓ Minimal space required
- ✓ Compliant with accident prevention regulations
- ✓ Quick response
- ✓ Splash-proof in every installation position
- ✓ Wide range of applications

Diaphragm Actuators

Pneumatic Actuators

General Data

Air supply, max.	6 bar
Ambient temperature	-20 to +80 °C (-40 to +90 °C)

Actuator Series 812

Size	MF I		MF III	
Stroke, max.	20 mm	30 mm	30 mm	60 mm
Diaphragm effective area	320 cm ²	320 cm ²	720 cm ²	720 cm ²
No. of springs	6	6	12	12
Actuating force, spring return, max.	6.3 kN	4.8 kN	16 kN	14 kN
Actuating force, air, max.	14.4 kN	14.4 kN	32.4 kN	32.4 kN

Actuator Series 811

Size	UMA 0	UMA I	UMA III	UMA V
Stroke, max.	20 mm	30 mm	60 mm	120 mm
Diaphragm effective area	210 cm ²	320 cm ²	720 cm ²	1440 cm ²
No. of springs	1	1	1	1
Actuating force, spring return, max.	4.5 kN	7.7 kN	17.3 kN	33.1 kN
Actuating force, air, max.	11.6 kN	17.8 kN	39.5 kN	81.2 kN

Actuator Series MA

Size	16	21	31	41	60
Stroke, max.	20 mm	35 mm	59 mm	118 mm	136 mm
Diaphragm effective area	85–110 cm ²	150–240 cm ²	355–550 cm ²	600–1135 cm ²	1500–2185 cm ²
No. of springs	7	7	7	14	16
Actuating force, spring return, max.	2.6 kN	4.3 kN	8.4 kN	25.2 kN	45 kN
Actuating force, air, max.	4.6 kN	8.5 kN	22.4 kN	40.5 kN	87 kN

Quarter-turn actuator Series 840

Size	841	842	843	844
Valve opening angle	0–60° / 0–90° / 30–90°			
Diaphragm effective area	104 cm ²	360 cm ²	470 cm ²	780 cm ²
No. of springs	1	1	1	1
Actuating torque, spring return, max.	46 Nm	253 Nm	715 Nm	1630 Nm
Actuating torque, air, max.	87 Nm	460 Nm	1345 Nm	2295 Nm

ARCA Regler GmbH

Kempener Strasse 18, Postfach 2120, D-47913 Tönisvorst
 Phone +49 (0)2156-7709-0, Fax +49 (0)2156 7709-55
www.arca-valve.com, sale@arca-valve.com

ARCA Flow Group worldwide: Competence in valves, pumps & cryogenics

