



HMIX Hydraulic Cylinders with Integrated Transducers

Metric feedback cylinders for working pressures
up to 210 bar

aerospace
climate control
electromechanical
filtration
fluid & gas handling
hydraulics
pneumatics
process control
sealing & shielding



ENGINEERING YOUR SUCCESS.

Introduction

The addition of a transducer and conditioning electronics to a hydraulic cylinder creates a system which responds rapidly and accurately to control signals for position and velocity, without the need for mechanical re-setting. By combining the sophistication of electronics with the enormous power densities offered by hydraulic motion, greater machine flexibility is achieved and set-up times are cut to a minimum.

Applications

Position feedback systems are suitable for precision control in a wide variety of applications, including:

- Machine tools
- Robots
- Flight simulators
- Woodworking machinery
- Paper machinery
- Valve mechanisms
- Injection moulding equipment
- Marine stabilisation systems
- Rubber processing equipment
- Aerial and antennae positioning systems
- Welding equipment
- Wind turbine blade pitch control

HMIX Series Cylinders

The HMIX series of electro-hydraulic cylinders is based on Parker's proven HMI metric tie rod cylinder range and is suitable for working pressures of up to 210 bar. A typical HMIX model comprises a single rod cylinder with integrated transducer and manifold, and is supplied ready to accept a suitable valve.

Cylinder specification details, eg: accessories, forces and cushioning, which are not specified in this catalogue, can be found in the HMI/HMD Series cylinder catalogue – please ask your Parker sales office for catalogue number HY07-1150/UK. Full details of suitable valves for use with HMIX electro-hydraulic cylinders can be found in catalogue number HY11-3341/UK.

Contents

	Page
HMIX Series Mounting Styles	3
Design Features and Benefits	4
Cylinder Dimensions	6
Piston Rod End Selection	10
Piston Rod End Dimensions	10
Dimensions – with Manifold Fitted	11
Manifold Dimensions and Patterns	12
Flow Rates and Valve Sizes	13
Transducer Connection	14
Technical Data – Transducer	14
Mounting Information	15
Maximum Operating Pressures	15
Seals and Fluid Data	16
Seal Kits for Pistons and Glands	16
Service Assembly Parts	17
Model Code	18

Parker Offers the Widest Range of Industrial Cylinders

Parker Hannifin's Cylinder Division is the world's largest supplier of hydraulic cylinders for industrial applications.

Parker manufactures a vast range of standard and special tie rod, roundline and 'mill' type cylinders to suit all types of industrial cylinder applications. Our cylinders are available to ISO, DIN, NFPA, ANSI and JIC standards, with other certifications available on request. All Parker hydraulic cylinders are designed to deliver long, efficient service with low maintenance requirements, guaranteeing high productivity year after year.

About Parker Hannifin

Parker Hannifin is the global leader in motion and control technologies, partnering with its customers to increase their productivity and profitability. The company employs more than 52,000 people in 48 countries, providing customers with technical excellence and first class customer service.

Visit us at www.parker.com



WARNING – USER RESPONSIBILITY

FAILURE OR IMPROPER SELECTION OR IMPROPER USE OF THE PRODUCTS DESCRIBED HEREIN OR RELATED ITEMS CAN CAUSE DEATH, PERSONAL INJURY AND PROPERTY DAMAGE.

This document and other information from Parker-Hannifin Corporation, its subsidiaries and authorized distributors provide product or system options for further investigation by users having technical expertise.

The user, through its own analysis and testing, is solely responsible for making the final selection of the system and components and assuring that all performance, endurance, maintenance, safety and warning requirements of the application are met. The user must analyze all aspects of the application, follow applicable industry standards, and follow the information concerning the product in the current product catalog and in any other materials provided from Parker or its subsidiaries or authorized distributors.

To the extent that Parker or its subsidiaries or authorized distributors provide component or system options based upon data or specifications provided by the user, the user is responsible for determining that such data and specifications are suitable and sufficient for all applications and reasonably foreseeable uses of the components or systems.

Offer of Sale

Please contact your Parker representation for a detailed "Offer of Sale".

HMIX Series Mounting Styles

HMIX cylinders are available in eight standard mounting styles, based on ISO 6020/2. Basic cylinder dimensions are shown on

pages 6 to 10, with additional dimensions for manifold blocks shown on pages 11 to 13.

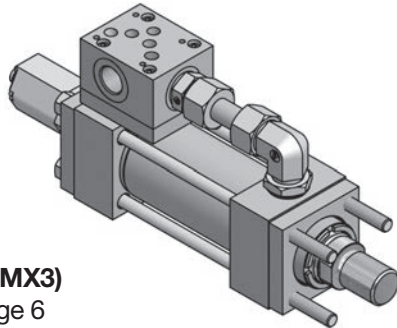

TB (ISO MX3)
– see page 6

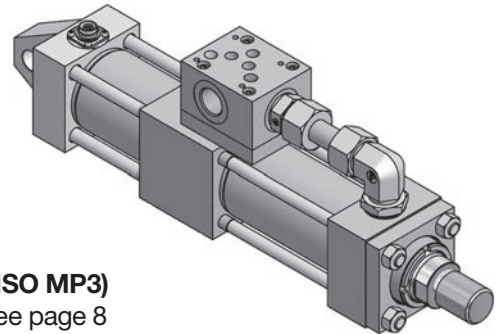

B (ISO MP3)
– see page 8

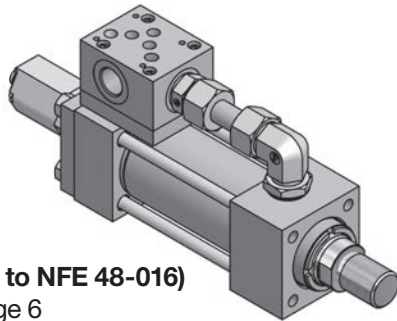

TE (MX5 to NFE 48-016)
– see page 6

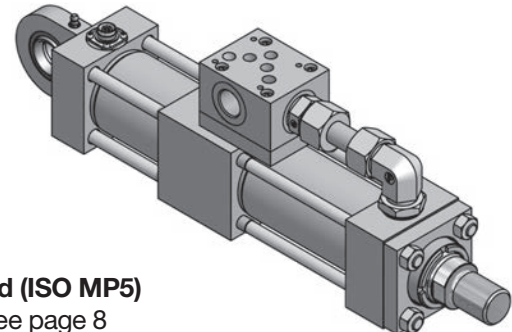

SBd (ISO MP5)
– see page 8

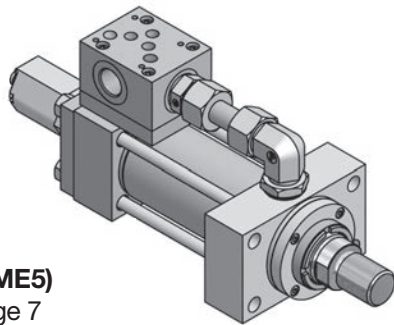

JJ (ISO ME5)
– see page 7

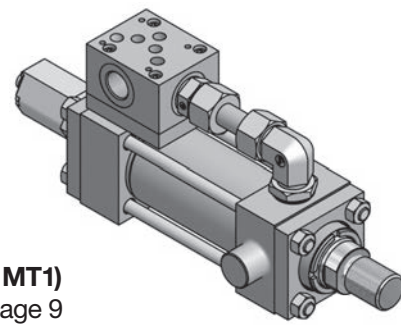

D (ISO MT1)
– see page 9

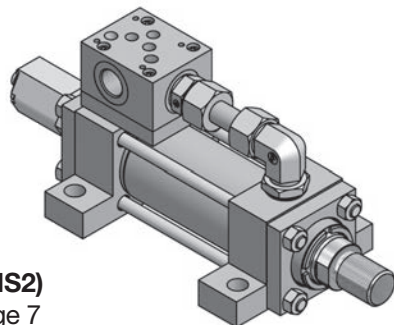

C (ISO MS2)
– see page 7

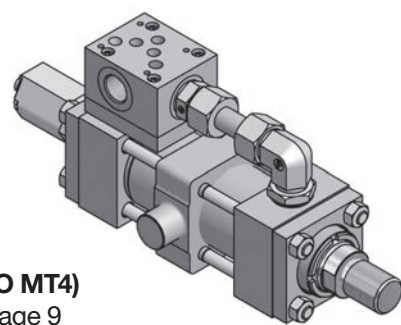

DD (ISO MT4)
– see page 9

A High Precision, Magnetostrictive Transducer

The magnetostrictive transducers fitted to HMIX cylinders provide analogue or digital information of actuator position through the interaction of two magnetic fields. In closed loop feedback applications, these transducers deliver accurate information of position, velocity and acceleration over the full stroke of the cylinder. In open loop systems, a transducer may be used as a continuous, infinite resolution position monitoring device.

- non-contacting design delivers long working life
- internal transducer protects sensitive components, ensuring accuracy and reliability
- steel protection tube prevents physical damage to transducer electronics module
- Compact design adds little to overall build length, simplifying machine design

Where a rear pivot-mounted cylinder is required, eg: Styles B or SBd, a 'dummy cylinder' is constructed to house the electronics module. See page 8.

Transducer Specification

Type	magnetostrictive, absolute, non-contacting
Mounting Position	internal
Stroke length	25-3000mm
Max speed	1.5m/s
Operating temperature	-40°C to +85°C
Outputs	analogue and digital
Fluid suitability	all
Environment	medium levels of shock and vibration

The technical specification of the transducer is shown on page 14.

A Fully Integrated Manifold

HMIX is supplied with a pre-fitted manifold block, ready to accept your choice of valve. With pipework and connections already in place, assembly time is cut to a minimum and performance is guaranteed.

- Directly-mounted valve blocks deliver precise positional accuracy and simplify installation
- Manifolds are available for different valve sizes, to deliver the power and speed the machine requires
 - DIN NG6 / CETOP03 / NFPA D03
 - DIN NG10 / CETOP05 / NFPA D05
 - DIN NG16 / CETOP07 / NFPA D07
- Manifolds are offered for all common valve sizes. Their pattern corresponds to DIN 24340, ISO 4401 and ETOP RP121.

Full details of HMIX manifold blocks for valve assemblies are shown on pages 12 and 13.

How does a magnetostrictive transducer work?

The two magnetic fields which are central to the operation of the magnetostrictive transducer are generated by a permanent magnet on the actuator piston, and by a magnetic pulse produced by a current pulse launched along a copper core inside the waveguide tube. The interaction between the two fields produces a torsional strain pulse, which travels down the waveguide tube and is sensed by a coil at the end of the device. The position of the permanent magnet is established by measuring the elapsed time between the launching of the current pulse and the arrival of the strain pulse. Interface electronics convert this information to a digital or analogue output.

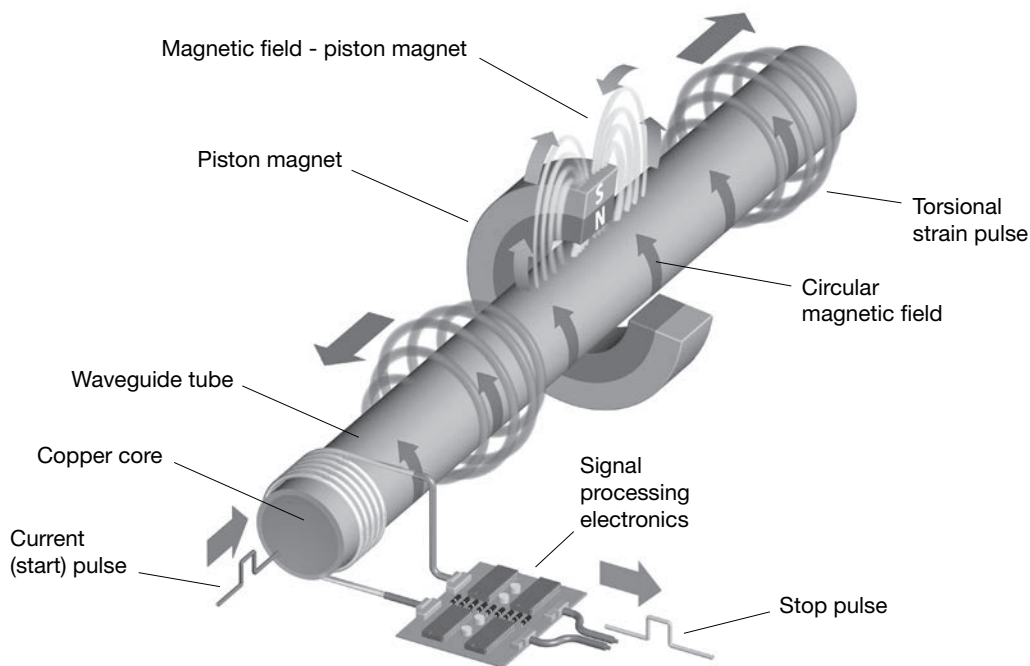

A Robust, High Performance Tie Rod Cylinder

The HMIX cylinder is based on Parker's established HMI tie rod hydraulic cylinder range, proven in countless industrial applications around the world.

Parker's expertise in cylinder design delivers a premium quality, cost effective solution for the design engineer and high productivity and low whole-life costs for the end user.

- exceptionally compact dimensions to simplify machine design
- a wide range of mounting styles provides the optimum choice for each application
- a range of rod end styles to simplify design and maintenance

HMIX cylinders meet the requirements of ISO 6020/2 and are suitable for working pressures up to 210 bar.

Cylinder Specification

Bore sizes	40-200mm
Rod sizes	28-140mm
Stroke	up to 3000mm
Max. speed	1.0m/s
Operating temp.	-20°C to +85°C
Fluid media	all common fluid types including water glycol

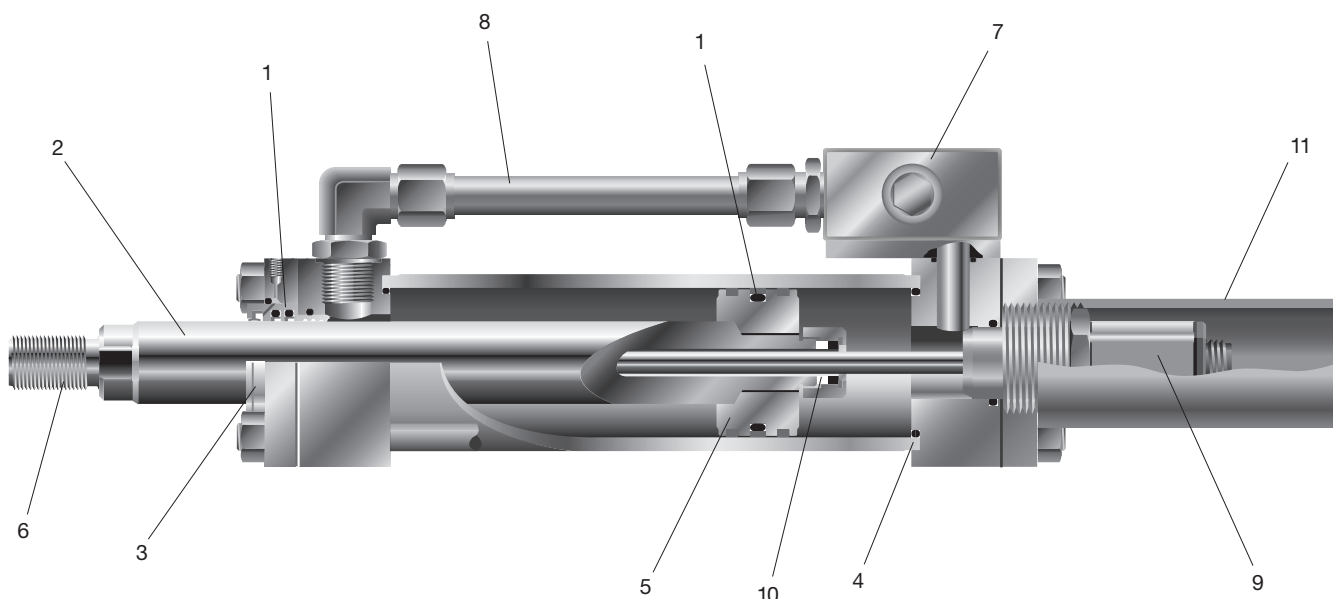

- 1 Low friction seals**
– ensure smooth break-out and high performance at low speeds and pressures
- 2 High tensile, carbon alloy steel piston rods**
– for long life and high impact resistance
- 3 Replaceable rod gland**
– for quick, easy maintenance and high productivity
- 4 Pressure-energised body seals**
– prevent leakage, even under pressure shock conditions
- 5 One-piece steel piston**
– mechanically locked to the piston rod, delivers long, reliable service life
- 6 Male or female rod ends**
– with a choice of two or four spanner flats to ease access in confined spaces

- 7 Precision machined steel manifold**
– optimises valve/actuator performance
- 8 Rugged steel pipework and fittings**
– to withstand the toughest working environments
- 9 A sophisticated magnetostrictive transducer**
– delivering exceptional resolution and repeatability over millions of cycles
- 10 Non-contacting permanent magnets**
– for reliable signal generation under all conditions
- 11 A heavy duty steel sleeve**
– protects both the transducer electronics module and its connector

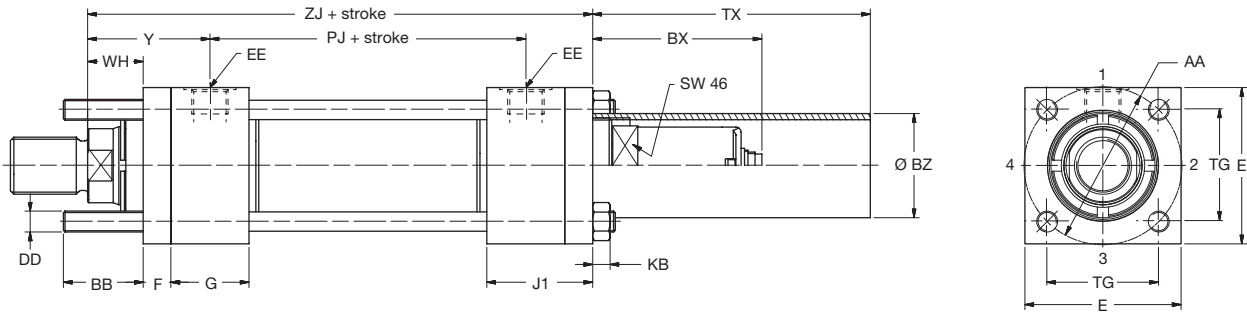

Style TB

Tie Rods Extended at Head End
 ISO Style MX3

See Notes 1, 2

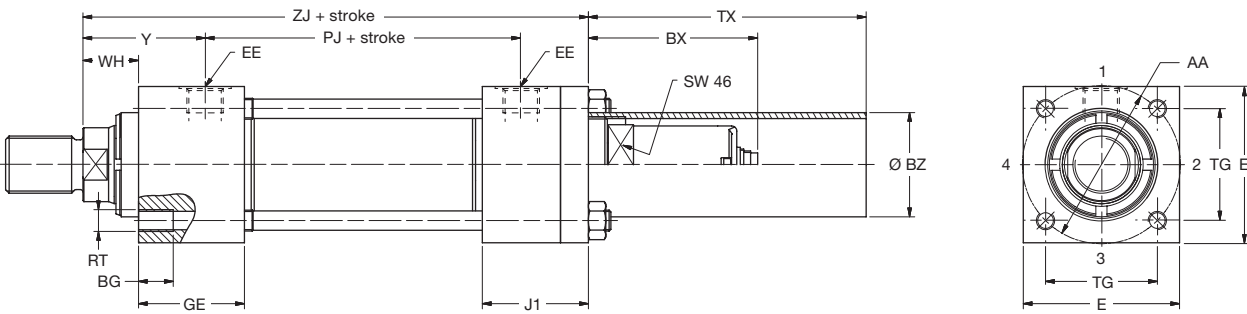

Style TE

Threaded Holes at Head End
 NF E48-016 Style MX5

See Notes 1, 2

Dimensions – TB & TE For rod end dimensions, see page 10

Bore Ø	AA	BB	BG min	BX max	BZ max	DD	E	EE ¹ (BSPP) inches	F max	G	GE	J1	KB	RT	TG	TX	WH	Y	+ Stroke	
																			PJ	ZJ
40	59	35	12	121	54 ²	M8x1	64	G ³ / ₈	10	45	55	55	6.5	M8	41.7	-	25	62	73	170
50	74	46	18	115	54 ²	M12x1.25	76	G ¹ / ₂	16	45	61	61	10	M12	52.3	-	25	67	74	182
63	91	46	18	98	60	M12x1.25	90	G ¹ / ₂	16	45	61	61	10	M12	64.3	160	32	71	80	191
80	117	59	24	94	60	M16x1.5	115	G ³ / ₄	20	50	70	70	13	M16	82.7	160	31	77	93	215
100	137	59	24	92	60	M16x1.5	130	G ³ / ₄	22	50	72	72	13	M16	96.9	160	35	82	101	230
125	178	81	27	114	60	M22x1.5	165	G1	22	58	80	58	18	M22	125.9	176	35	86	117	232
160	219	92	32	114	60	M27x2	205	G1	25	58	83	58	22	M27	154.9	176	32	86	130	245
200	269	115	40	114	60	M30x2	245	G1 ¹ / ₄	25	76	101	76	24	M30	190.2	176	32	98	165	299

¹ Standard port thread if no manifold is fitted.

² Across corners dimension of transducer nut. A protection tube is not available for 40mm and 50mm bore sizes.

All dimensions are in millimetres unless otherwise stated.

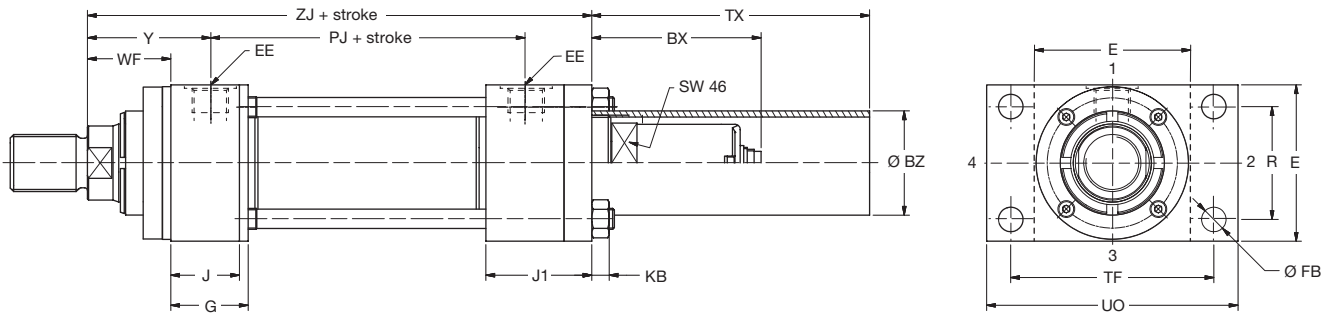

Style JJ
 Head Rectangular Flange
 ISO Style ME5

See Notes 1, 2, 3, 4

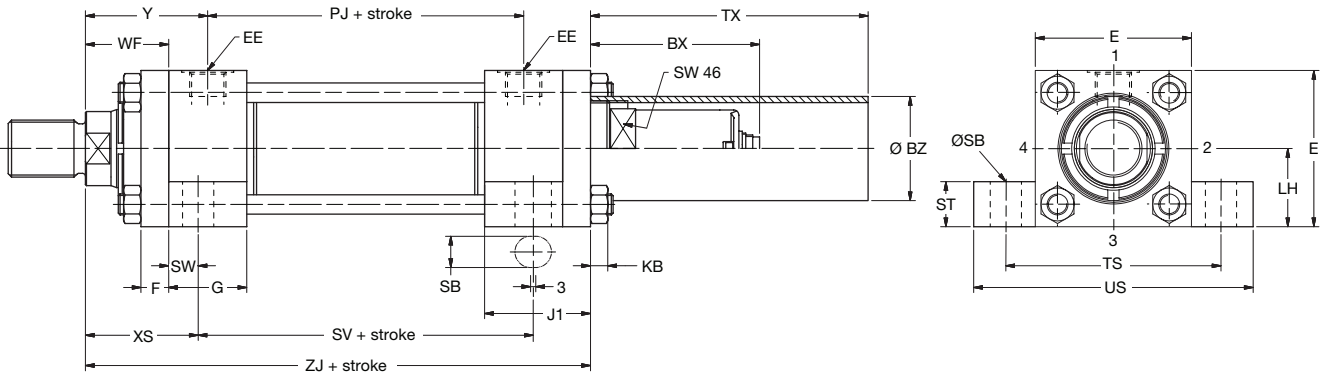

Style C
 Side Lugs
 ISO Style MS2

See Notes 1, 2, 5

Dimensions – JJ & C For rod end dimensions, see page 10

Bore Ø	BX max	BZ max	E	EE ¹ (BSPP) inches	F max	FB	G	J ⁴	J1	KB	LH h10	R	SB	ST	SW	TF	TS	TX	UO	US	WF	XS	Y	+ Stroke		
																								PJ	SV	ZJ
40	121	54 ²	64	G ³ / ₈	10	11	45	38	55	6.5	31	41	11	12.5	10	87	83	-	110	103	35	45	62	73	105	170
50	115	54 ²	76	G ¹ / ₂	16	14	45	38	61	10	37	52	14	19	13	105	102	-	130	127	41	54	67	74	99	182
63	98	60	90	G ¹ / ₂	16	14	45	38	61	10	44	65	18	26	17	117	124	160	145	161	48	65	71	80	93	191
80	94	60	115	G ³ / ₄	20	18	50	45	70	13	57	83	18	26	17	149	149	160	180	186	51	68	77	93	110	215
100	92	60	130	G ³ / ₄	22	18	50	45	72	13	63	97	26	32	22	162	172	160	200	216	57	79	82	101	107	230
125	114	60	165	G1	22	22	58	58	58	18	82	126	26	32	22	208	210	176	250	254	57	79	86	117	131	232
160	114	60	205	G1	25	26	58	58	58	22	101	155	33	38	29	253	260	176	300	318	57	86	86	130	130	245
200	114	60	245	G1 ¹ / ₄	25	33	76	76	76	24	122	190	39	44	35	300	311	176	360	381	57	92	98	165	172	299

¹ Standard port thread if no manifold is fitted.

² Across corners dimension of transducer nut. A protection tube is not available for 40mm and 50mm bore sizes.

³ A one-piece head is fitted to 40mm bore cylinders.

⁴ Head end dimensions to DIN 24554 are available as an option.

⁵ A thrust key may be used with this mounting style – see page 15.

All dimensions are in millimetres unless otherwise stated.

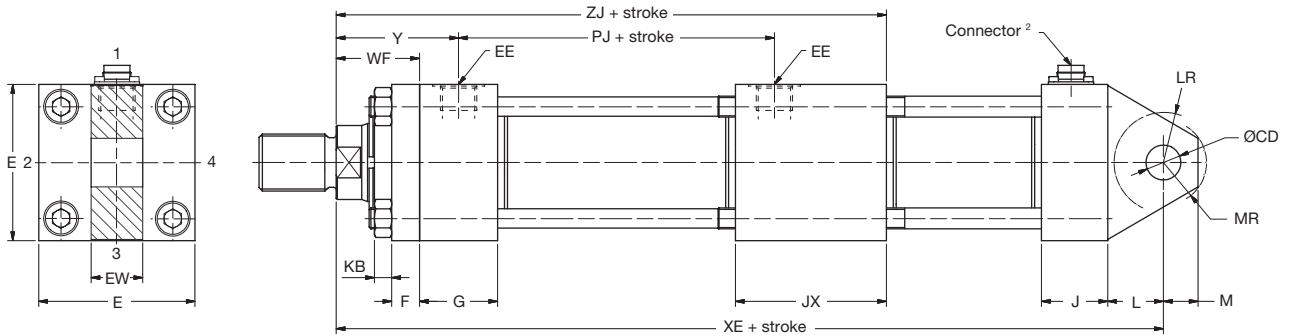

Style B
 Cap Fixed Eye
 ISO Style MP3

See Notes 1, 2, 3

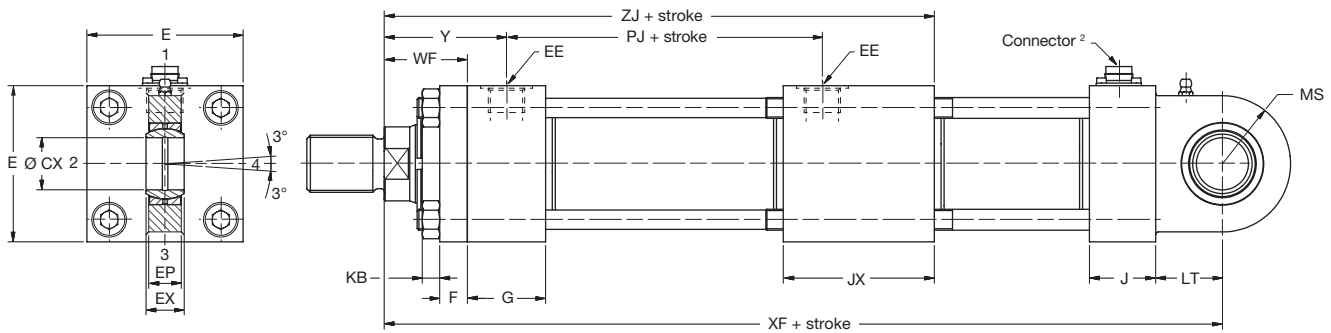

Style SBd
 Cap Fixed Eye with Spherical Bearing
 ISO Style MP5

See Notes 1, 2, 3, 4

Dimensions – B & SBd For rod end dimensions, see page 10

Bore Ø	CD H9	CX	E	EE ¹ (BSPP) inches	EP	EW h14	EX	F max	G	J	JX	KB	L	LR	LT	M	MR	MS max	WF	Y	+ Stroke			
																					PJ	XE	XF	ZJ
40	14	20 ^{-0.012}	64	G ³ / ₈	13	20	16	10	45	38	77	6.5	19	17	25	14	16	29	35	62	73	354	360	192
50	20	25 ^{-0.012}	76	G ¹ / ₂	17	30	20	16	45	38	87	10	32	29	31	20	25	33	41	67	74	366	365	208
63	20	30 ^{-0.012}	90	G ¹ / ₂	19	30	22	16	45	38	87	10	32	29	38	20	25	40	48	71	80	377	383	217
80	28	40 ^{-0.012}	115	G ³ / ₄	23	40	28	20	50	45	84	13	39	34	48	28	34	50	51	77	93	401	410	229
100	36	50 ^{-0.012}	130	G ³ / ₄	30	50	35	22	50	45	74	13	54	50	58	36	44	62	57	82	101	432	436	232
125	45	60 ^{-0.015}	165	G1	38	60	44	22	58	58	58	18	57	53	72	45	53	80	57	86	117	472	487	232
160	56	80 ^{-0.015}	205	G1	47	70	55	25	58	58	58	22	63	59	92	59	59	100	57	86	130	499	528	245
200	70	100 ^{-0.020}	245	G ¹ / ₄	57	80	70	25	76	76	76	24	82	78	116	70	76	120	57	98	165	598	632	299

¹ Standard port thread if no manifold is fitted.

² The connector is supplied in position 1 (illustrated) as standard.

³ A pivot pin is not supplied with the cylinder.

⁴ The M6 grease nipple illustrated is fitted to cylinders of 50mm bore and above. 40mm bore cylinders have a 2.5mm drilling for lubrication.

All dimensions are in millimetres unless otherwise stated.

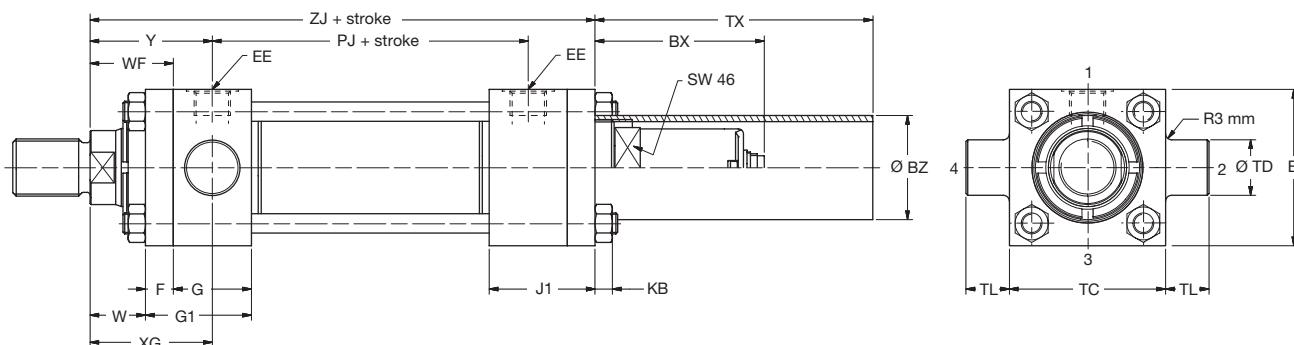

Style D
 Head Trunnion
 ISO Style MT1

See Notes 1, 2, 5

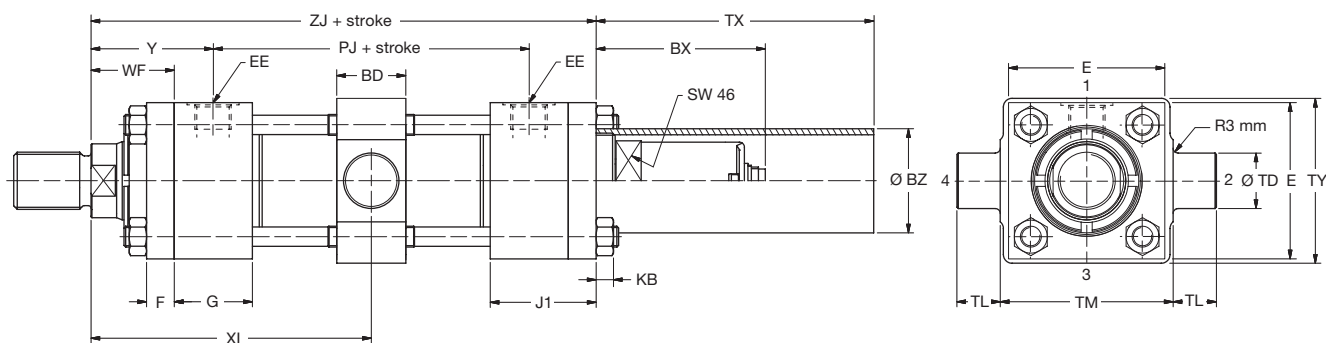

Style DD
 Intermediate Fixed Trunnion
 ISO Style MT4

See Notes 1, 2, 3, 4

Dimensions – D & DD For rod end dimensions, see page 10

Bore Ø	BD	BX max	BZ max	E	EE ¹ (BSPP) inches	F max	G	G1	J1	KB	TC	TD f8	TL	TM	TX	TY	W	WF	XG	Y	+ Stroke		Style DD min stroke ³	Min XI dim'n ⁴
																					PJ	ZJ		
40	30	121	54 ²	64	G ³ / ₈	10	45	-	55	6.5	63	20	16	76	-	76	-	35	57	62	73	170	15	97
50	40	115	54 ²	76	G ¹ / ₂	16	45	-	61	10	76	25	20	89	-	89	-	41	64	67	74	182	15	107
63	40	98	60	90	G ¹ / ₂	16	45	-	61	10	89	32	25	100	160	95	-	48	70	71	80	191	15	114
80	50	94	60	115	G ³ / ₄	20	50	-	70	13	114	40	32	127	160	127	-	51	76	77	93	215	20	127
100	60	92	60	130	G ³ / ₄	22	50	72	72	13	127	50	40	140	160	140	35	57	71	82	101	230	20	138
125	73	114	60	165	G1	22	58	80	58	18	165	63	50	178	176	178	35	57	75	86	117	232	25	153
160	90	114	60	205	G1	25	58	88	58	22	203	80	63	215	176	216	32	57	75	86	130	245	30	161
200	110	114	60	245	G1 ¹ / ₄	25	76	108	76	24	241	100	80	279	176	280	32	57	85	98	165	299	30	190

¹ Standard port thread if no manifold is fitted.

² Across corners dimension of transducer nut. A protection tube is not available for 40mm and 50mm bore sizes.

³ Without manifold fitted at end cap, otherwise see page 11.

⁴ XI Dimension to be specified by customer

⁵ A one-piece head and retainer is used on 100-200mm bore sizes – see G1 dimension. On 160 and 200mm bores, the bolted gland is recessed, with tie rods screwed into the head.

All dimensions are in millimetres unless otherwise stated.

Rod End Selection

Rod ends can be supplied with two or four wrench flats. The desired combination of rod diameter, rod end thread and number of wrench flats can be identified from the table below and selected in the order code on pages 18-19. Note the Maximum Operating Pressure information in the table on page 15.

The WH dimension for mounting styles TB and TE is shown on page 6.

Rod End Codes 5 and 9 – Short Stroke Cylinders

Code 5 or 9 (female) rod ends should not be used on 160mm or 200mm bore cylinders with a stroke of 50mm or less. Please consult the factory, with details of the application.

Rod End Code 3

Non-standard piston rod ends are designated Code 3. A dimensional sketch or description should accompany the order. Please specify dimensions KK or KF, A, rod stand out (WF – VE) and thread form.

Rod End Codes 1, 2, 4 & 7 – All Except JJ Mount

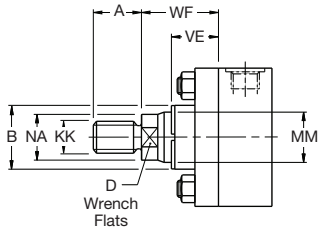

Rod End Codes 1, 2, 4 & 7 – JJ Mount

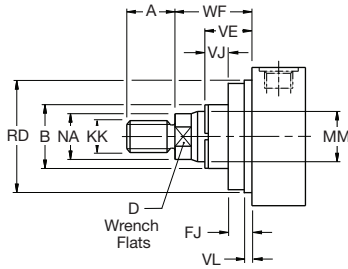

Rod End Codes 5 & 9 – All Except JJ Mount

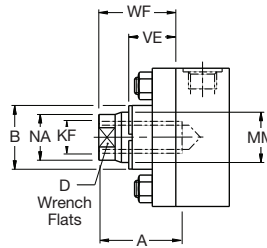

Rod End Codes 5 & 9 – JJ Mount

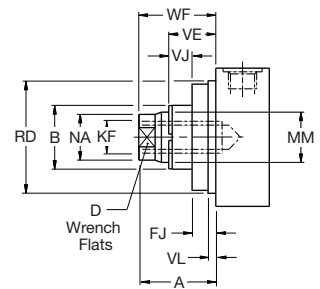

Piston Rod End Dimensions

– Check Maximum Operating Pressure on page 15

Bore Ø	Rod No.	Rod Ø
		MM
40	2	28
50	2	36
	3	28
63	1	28
	2	45
	3	36
80	1	36
	2	56
	3	45
100	1	45
	2	70
	3	56
125	1	56
	2	90
	3	70
160	1	70
	2	110
	3	90
200	1	90
	2	140
	3	110

Code 1 (4 Flats) and Code 4 (2 Flats)		Code 2 (4 Flats) and Code 7 (2 Flats)		Code 5 (4 Flats) and Code 9 (2 Flats)		B _{f9}	D	NA	VE	WF
KK	A	KK	A	KF	A					
M20x1.5	28	M14x1.5	18	M20x1.5	28	42	22	26	22	35
M27x2	36	M16x1.5	22	M27x2	36	50	30	34	25	41
M20x1.5	28	M16x1.5	22	M20x1.5	28	42	22	26	22	48
M20x1.5	28	–	–	M20x1.5	28	42	22	26	22	51
M33x2	45	M20x1.5	28	M33x2	45	60	39	43	29	57
M27x2	36	M20x1.5	28	M27x2	36	50	30	34	25	57
M27x2	36	–	–	M27x2	36	50	30	34	25	57
M42x2	56	M27x2	36	M42x2	56	72	48	54	29	57
M33x2	45	M27x2	36	M33x2	45	60	39	43	29	57
M33x2	45	–	–	M33x2	45	60	39	43	29	57
M48x2	63	M33x2	45	M48x2	63	88	62	68	32	57
M42x2	56	M33x2	45	M42x2	56	72	48	54	29	57
M42x2	56	–	–	M42x2	56	72	48	54	29	57
M64x3	85	M42x2	56	M64x3	85	108	80	88	32	57
M48x2	63	M42x2	56	M48x2	63	88	62	68	32	57
M48x2	63	–	–	M48x2	63	88	62	68	32	57
M80x3	95	M48x2	63	M80x3	95	133	100	108	32	57
M64x3	85	M48x2	63	M64x3	85	108	80	88	32	57
M64x3	85	–	–	M64x3	85	108	80	88	32	57
M100x3	112	M64x3	85	M100x3	112	163	128	138	32	57
M80x3	95	M64x3	85	M80x3	95	133	100	108	32	57

JJ Mount only			
VL min	RD f8	VJ	FJ
3	62	12	10
4	74	9	16
		6	
4	75	6	16
		88	
4	82	13	20
		9	
4	105	5	20
		9	
5	92	7	22
		10	
5	125	7	22
		7	
5	105	9	20
		9	
5	150	10	22
		10	
5	125	10	22
		10	
5	170	7	25
		7	
5	150	10	22
		10	
5	210	7	25
		7	

All dimensions are in millimetres unless otherwise stated.

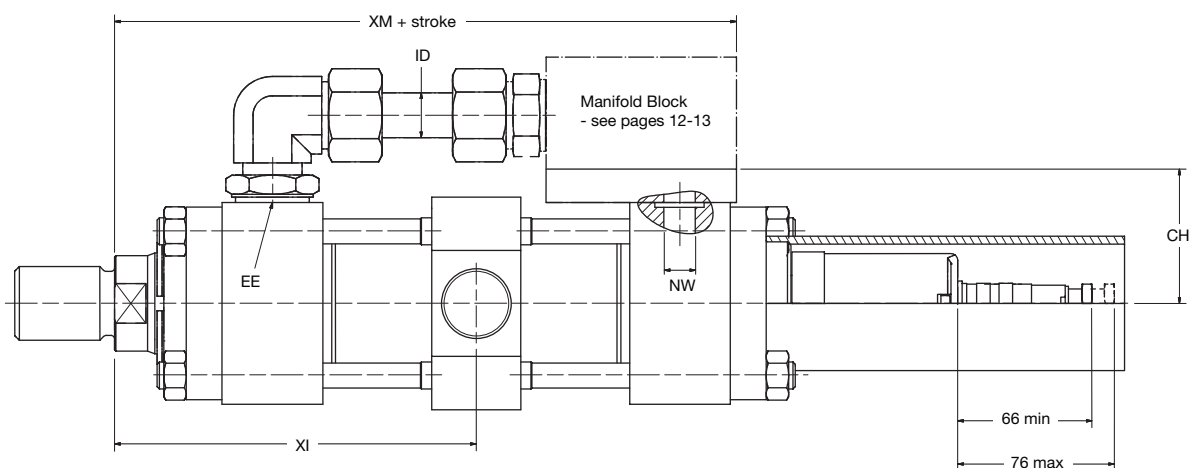

Styles C, D, DD, JJ, TB, TE
 Style DD illustrated

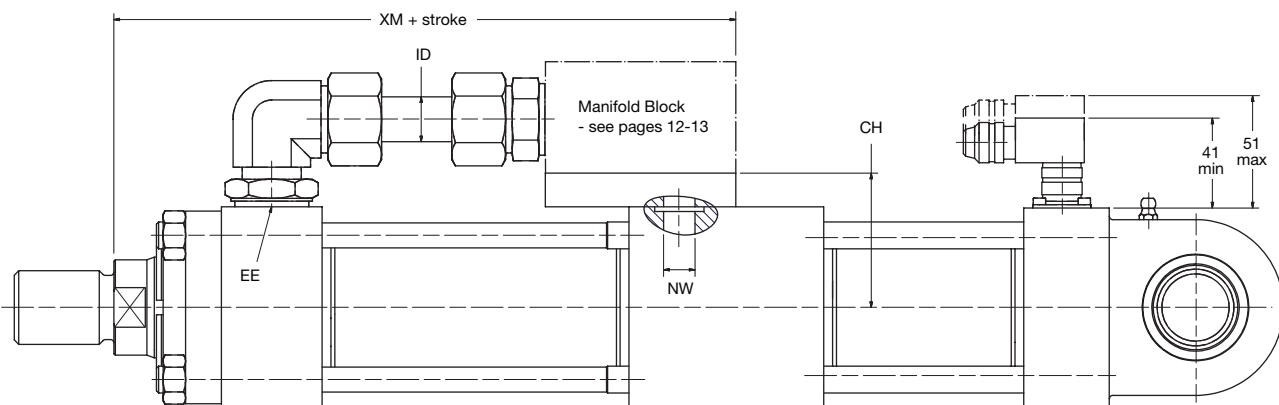

Styles B, SBd
 Style SBd illustrated

Dimensions – with Manifold Fitted For other dimensions, see pages 6 to 10

Bore Ø	ID Ø	EE	NW	With Standard Manifold Fitted						
				Minimum Stroke	XI min	+ Stroke		NG6 CH	NG10 CH	NG16 CH
						XI max	XM			
40	11	G ¹ / ₂	11	50	97	70	165	47		
50	11	G ¹ / ₂	11	45	107	75	171	53		
63	16	G ³ / ₄	14	80	114	67	193		60	
80	16	G ³ / ₄	14	76	127	80	210		73	
100	16	G ³ / ₄	14	76	138	85	223		80	
125	16	G ³ / ₄	14	56	153	100	243		98	
160	29	G ¹ / ₄	18	100	161	80	264			127
200	29	G ¹ / ₄	18	65	190	115	309			147

All dimensions are in millimetres unless otherwise stated.

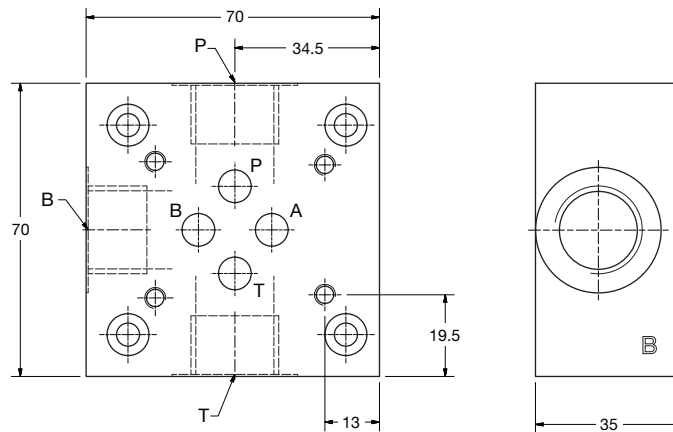

**Manifold for Valve Size
DIN NG6 / CETOP03 / NFPA D03**
Pattern corresponds to DIN 24340 / ISO 4401 / ETOP RP121

Port P – G^{1/2}
Port T – G^{1/2}
Port B – G^{1/2}

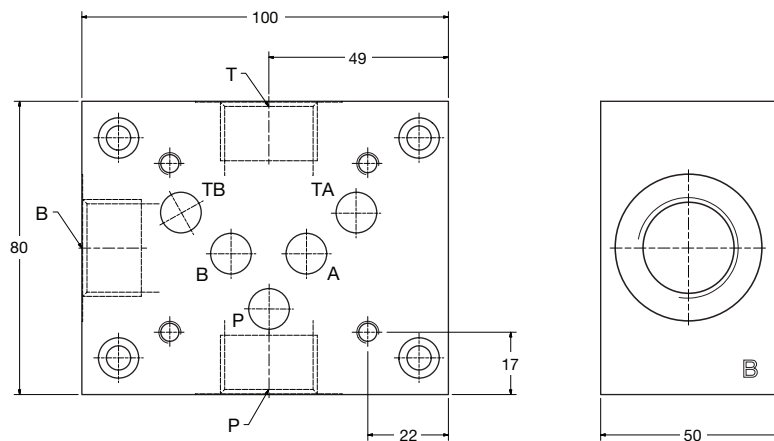

**Manifold for Valve Size
DIN NG10 / CETOP05 / NFPA D05**
Pattern corresponds to DIN 24340 / ISO 4401 / ETOP RP121

Port P – G^{3/4}
Port T – G^{3/4}
Port B – G^{3/4}

All dimensions are in millimetres unless otherwise stated.

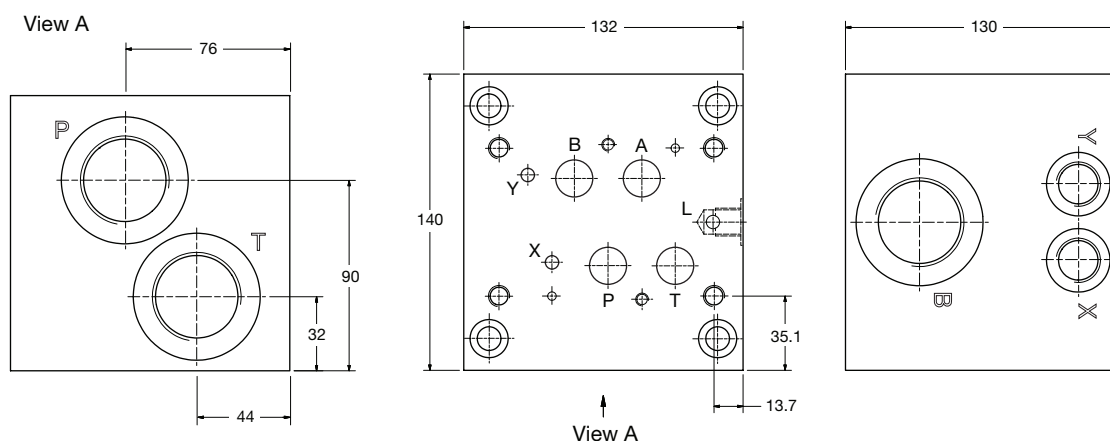

Manifold for Valve Size
DIN NG16 / CETOP07 / NFPA D07
 Pattern corresponds to DIN 24340 / ISO 4401 / ETOP RP121

Port P – G1¹/₄ Port X – G¹/₂
 Port T – G1¹/₄ Port Y – G¹/₂
 Port B – G1¹/₄

HMIX Flow Rates and Standard Valve Sizes

Bore Ø	Rod No. ¹	Rod Ø	Piston Area, Full Bore/Annular cm ²	Piston Area, Full Bore cm ²	Piston Area, Annular cm ²	Flow Rate @ 5m/s Fluid Velocity l/min		Manifold		
						AB / AR	AB	AR	Cap End	Head End
40	2	28	1.96	12.57	6.41	28.5	28.5	Std.	Special	N/A
	3	28	1.46	19.64	13.48	28.5	28.5	Std.	Special	N/A
50	1	28	1.25	31.18	25.02	46.2	60.3	Special	Std.	N/A
	2	45	2.04		15.27					
	3	36	1.48		21.00					
80	1	36	1.25	50.27	40.00	46.2	60.3	Special	Std.	N/A
	2	56	1.96		25.64					
	3	45	1.46		34.36					
100	1	45	1.25	78.55	62.64	46.2	60.3	Special	Std.	Special
	2	70	1.96		40.06					
	3	56	1.46		53.92					
125	1	56	1.25	122.72	98.09	46.2	60.3	Special	Std.	Special
	2	90	2.08		59.09					
	3	70	1.46		84.23					
160	1	70	1.24	201.06	162.57	94.2	198.2	Special	Special	Std.
	2	110	1.90		106.01					
	3	90	1.46		137.43					
200	1	90	1.25	314.16	250.53	94.2	198.2	Special	Special	Std.
	2	140	1.96		160.20					
	3	110	1.43		219.11					

¹ Rod No.3 does not conform to ISO 6020/2.

All dimensions are in millimetres unless otherwise stated.

Transducer Connection

Connection to the transducer electronics is via a straight or angled connector. Both types are suitable for use with all cylinder mounting styles. Pin connections are shown in the table.

Connector Pins	Sensor with Analogue Output Code A	Sensor with Analogue Output Code C	Sensor with Digital Output Codes S & T
1	Free	4 ... 20mA	+ Clock pulse
2	0V	0V	+ Data
3	10 ... 0V	Free	- Clock pulse
4	La	La	Must be free
5	0 ... 10V	Free	- Data
6	Ground	Ground	Ground
7	+24V	+24V	+24V
8	Lb	Lb	Must be free

La and Lb are programmable inputs which allow the user to set start and end positions remotely.

Connector Pin Arrangement
(Solder Pin View)

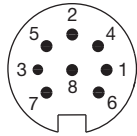

Straight Connector
Type LXES-0002

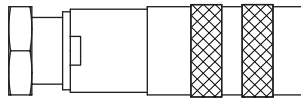

Right-Angled Connector
Type LXES-0003

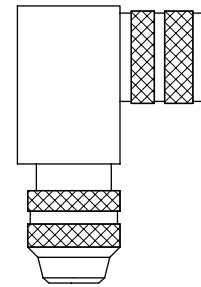

Technical Data

	Code A Voltage	Analogue Code C Current	Code T SSI	Digital Code S SSI
Output				
Signal	0-10V	4-20mA	24-bit Gray coded	24-bit Binary coded
Load current	≤ 5mA			
Load resistance		≤ 500 Ohm		
Resolution	≤ 0.33mV	≤ 0.66µA		5µm
Accuracy				
Linearity	± 50µm @ nominal length ≤ 500mm ± 0.01% FS @ nominal length > 500 to ≤ 5500mm		± 30µm	
Temperature coefficient	≤ 30 ppm / K		≤ 15 ppm / K	
Repeatability	± 0.3mV	± 0.6µA	± 1 digit	
Hysteresis	≤ 5µm		≤ 1 digit	
Ambient Conditions				
Operating temperature	-40°C to +85°C			
Protection class	IP67 when plug is connected			
Supply				
Voltage, stabilized			10-30V DC	
Ripple			≤ 0.5Vss	
Current draw (at 24V DC)	≤ 150mA		≤ 120mA	

Front Flange Mountings

Style JJ front flange-mounted cylinders, shown on page 7, incorporate a location diameter for accurate alignment on the mounting surface. The gland retainer is integral with the head on 40mm bore cylinders, while on 50mm bore sizes and above, the circular retainer is bolted to the head.

Extended Tie Rods

Cylinders may be ordered with extended tie rods in addition to another mounting style. The extended tie rods may then be used for mounting other systems or machine components. An additional set of mounting nuts is supplied.

Foot Mountings and Thrust Keys

The turning moment which results from the application of force by a foot-mounted cylinder (style C) must be resisted by secure mounting and effective guidance of the load. The option of a thrust key is recommended to provide positive cylinder location.

Foot-mounted cylinders use a separate key (supplied) fitted between keyways machined in the foot mounting at the head end of the cylinder and the machine bed. To order, select 'K' in the 'Mounting Modification' field of the model code on page 19. The key supplied corresponds to BS4235/DIN6885 type B.

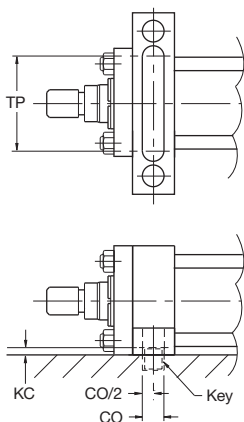

Bore Ø	CO N9	KC min	TP min	Key			
				Width	Height	Length	Part No.
40	12	4	55	12	8	55	0941540040
50	12	4.5	70	12	8	70	0941540050
63	16	4.5	80	16	10	80	0941540063
80	16	5	105	16	10	105	0941540080
100	16	6	120	16	10	120	0941540100
125	20	6	155	20	12	155	0941540125
160	32*	8	190	32	18	190	0941540160
200	40	8	220	40	22	220	0941540200

* Not to ISO 6020/2

Cylinder Cushioning

The HMI Series of cylinders, on which the HMIX electro-hydraulic cylinder range is based, is available with the option of cushions at either or both ends. Cushioning works by restricting the flow of hydraulic fluid to the port during the final millimetres of travel. This option is not recommended for HMIX cylinders in closed loop applications; where specified, the user should ensure that the cushioned distance is outside the working stroke range.

Gland Drains

The accumulation of fluid between the gland seals of long stroke cylinders, cylinders with low friction seals, cylinders with constant back pressure or where the ratio of the extend speed to the retract speed is greater than 2 to 1, can be relieved by specifying an optional gland drain. As a general guide, Parker recommends the use of a gland drain where piston speeds will exceed 0.6m/s and/or where the stroke length is:

- ≥ 30 x bore diameter for bore sizes up to and including 63mm
- ≥ 20 x bore diameter for bore sizes of 80mm and above.

Filtration

For maximum component life, the system should be protected from contamination by effective filtration. The rating of the filter medium depends on the system components and the application. The minimum required for hydraulic systems should be class 19/15 to ISO 4406, which equates to 25µ (b10 ≥75) to ISO 5472.

Maximum Operating Pressures

The recommended maximum operating pressures of cylinders fitted with a transducer are lower than those of the standard cylinder, due to the internal drilling of the piston rod. Maximum operating pressures for individual bore/rod combinations are shown in the table.

Bore Ø	Rod No.	Rod Ø	Max Operating Pressure
40	2	28	210
	3	28	180
50	1	28	100
	2	45	210
	3	36	210
63	1	36	130
	2	56	210
	3	45	210
80	1	45	120
	2	70	210
	3	56	210
100	1	56	140
	2	90	210
	3	70	200
125	1	70	110
	2	110	210
	3	90	210
160	1	90	130
	2	140	210
	3	110	210

All dimensions are in millimetres unless otherwise stated.

Seals and Fluid Data

Fluid Group	Seal Compounds – a combination of:	Fluid Medium to ISO 6743/4-2001	Temperature Range
1	NBR (nitrile butadiene rubber) PTFE (polytetrafluoroethylene) PUR (polyurethane)	Mineral Oil HH, HL, HLP, HLP-D, HM, HV, MIL-H-5606 oil, air, nitrogen	-20°C to +80°C
2	NBR (nitrile butadiene rubber) PTFE (polytetrafluoroethylene) PUR (polyurethane)	Water glycol (HFC)	-20°C to +60°C
5	FKM (fluorocarbon rubber) PTFE (polytetrafluoroethylene)	Fire resistant fluids based on phosphate esters (HFD-R). Also suitable for hydraulic oil at high temperatures or in hot environments. Not suitable for use with Skydrol. See fluid manufacturer's recommendations.	-20°C to +85°C

Seal Kits for Pistons and Glands

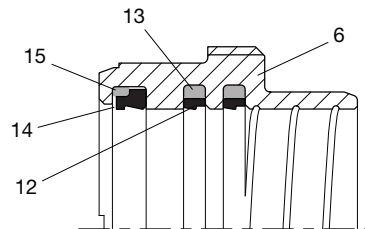
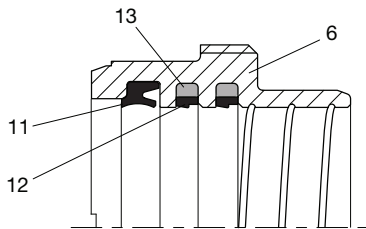

Low Friction Gland and Seals

Rod Ø	Low Friction Gland Service Cartridge Kit*
28	RG2HMF0281
36	RG2HMF0361
45	RG2HMF0451
56	RG2HMF0561
70	RG2HMF0701
90	RG2HMF0901
110	RG2HMF1101
140	RG2HMF1401

Ultra Low Friction Gland and Seals

Rod Ø	Ultra Low Friction Gland Service Cartridge Kit*
28	RG2HMU0281
36	RG2HMU0361
45	RG2HMU0451
56	RG2HMU0561
70	RG2HMU0701
90	RG2HMU0901
110	RG2HMU1101
140	RG2HMU1401

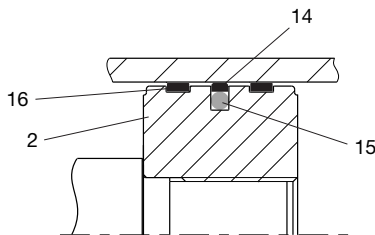

*** Replacement Seals – Ordering**

The part numbers shown in the tables are for fluid group 1 seals, denoted by the last character of each part number. For seals in fluid groups 2 or 5, substitute a '2' or '5' for the '1' at the end of the number sequence.

Key to Parts

- 1 Gland/bearing cartridge
- 2 Wiper seal
- 3 Step seal
- 4 Pre-load ring for step seal (3)
- 5 Scraper seal
- 6 Pre-load ring for scraper seal (5)
- 7 Piston
- 8 Wear ring
- 9 Piston seal
- 10 Energising ring for piston seal

Low Friction Piston

For use with Low Friction and Ultra Low Friction Glands

Bore Ø	Piston Service Kit Low Friction Seals*
40	PF040HM001
50	PF050HM001
63	PF063HM001
80	PF080HM001
100	PF100HM001
125	PF125HM001
160	PF160HM001
200	PF200HM001

All dimensions are in millimetres unless otherwise stated.

Sectioned View

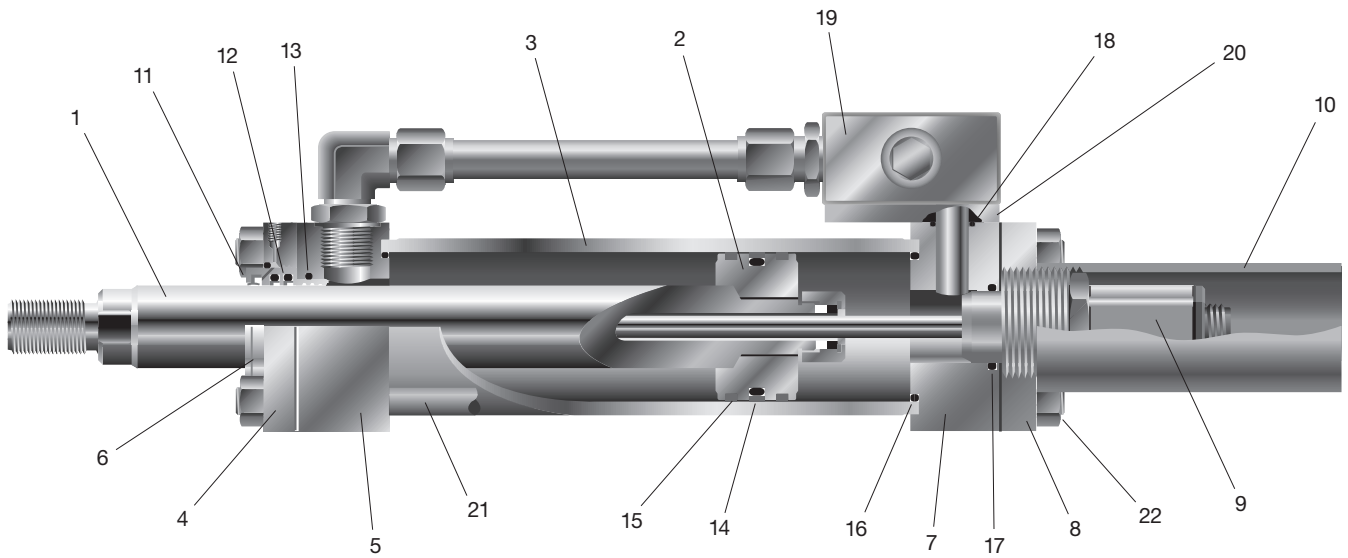

- 1 Piston rod
- 2 Piston
- 3 Cylinder tube
- 4 Retainer, head end
- 5 Cylinder head
- 6 Gland
- 7 Cylinder cap
- 8 Retainer, cap end
- 9 Transducer
- 10 Protective tube
(not available for bore sizes 40mm and 50mm)
- 11 Wiper seal ¹
- 12 Rod seals ¹

- 13 O-ring ¹
- 14 Piston seal ²
- 15 Piston wear rings ²
- 16 O-ring ²
- 17 O-ring
- 18 O-ring, adapter plate
- 19 Manifold
- 20 Subplate
- 21 Tie rod
- 22 Tie rod nut

¹ Included in Gland Service Kits and Gland Service Cartridge Kits
² Included in Piston Service Kits

How to Order

HMIX Series

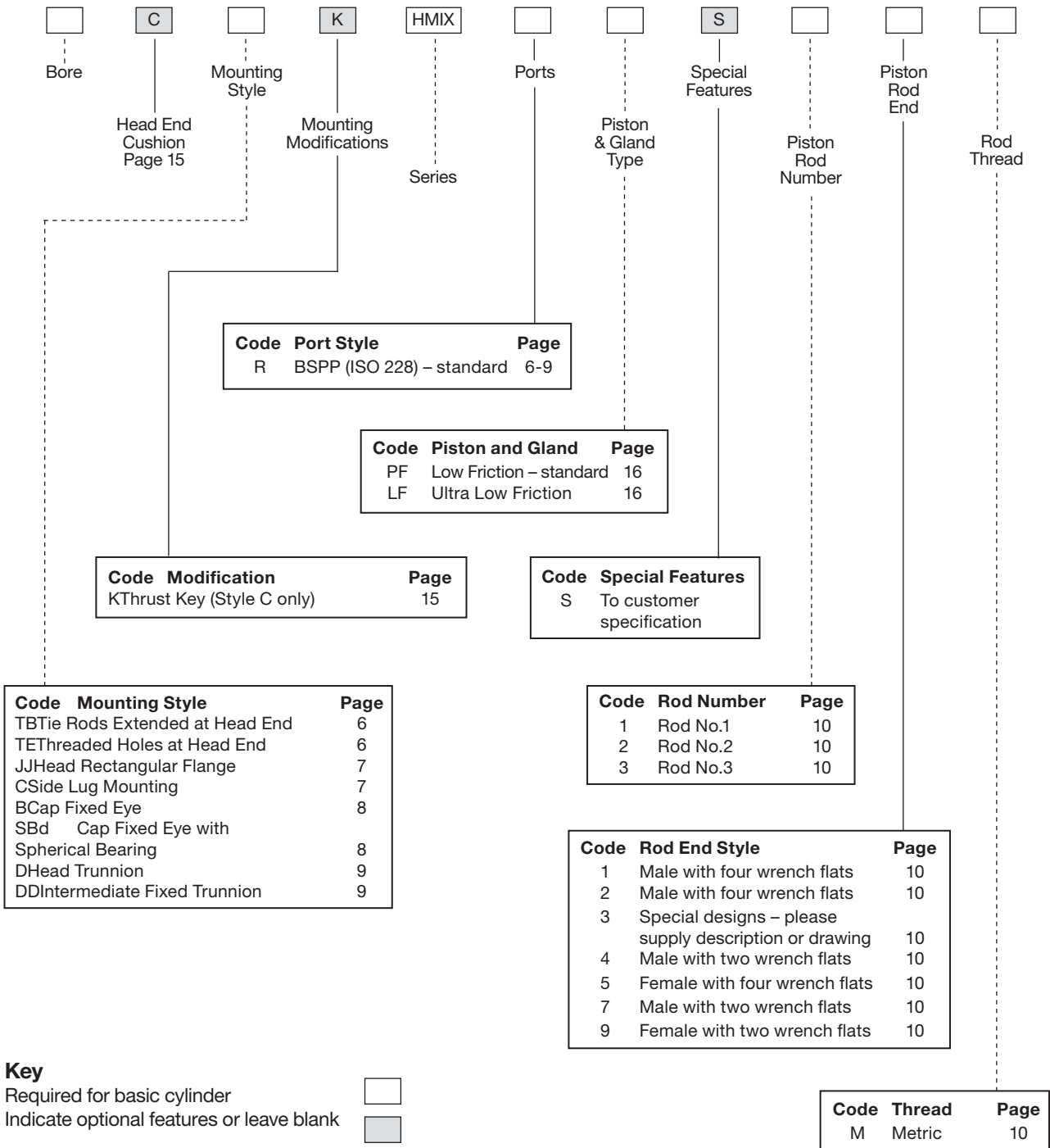

How to Order

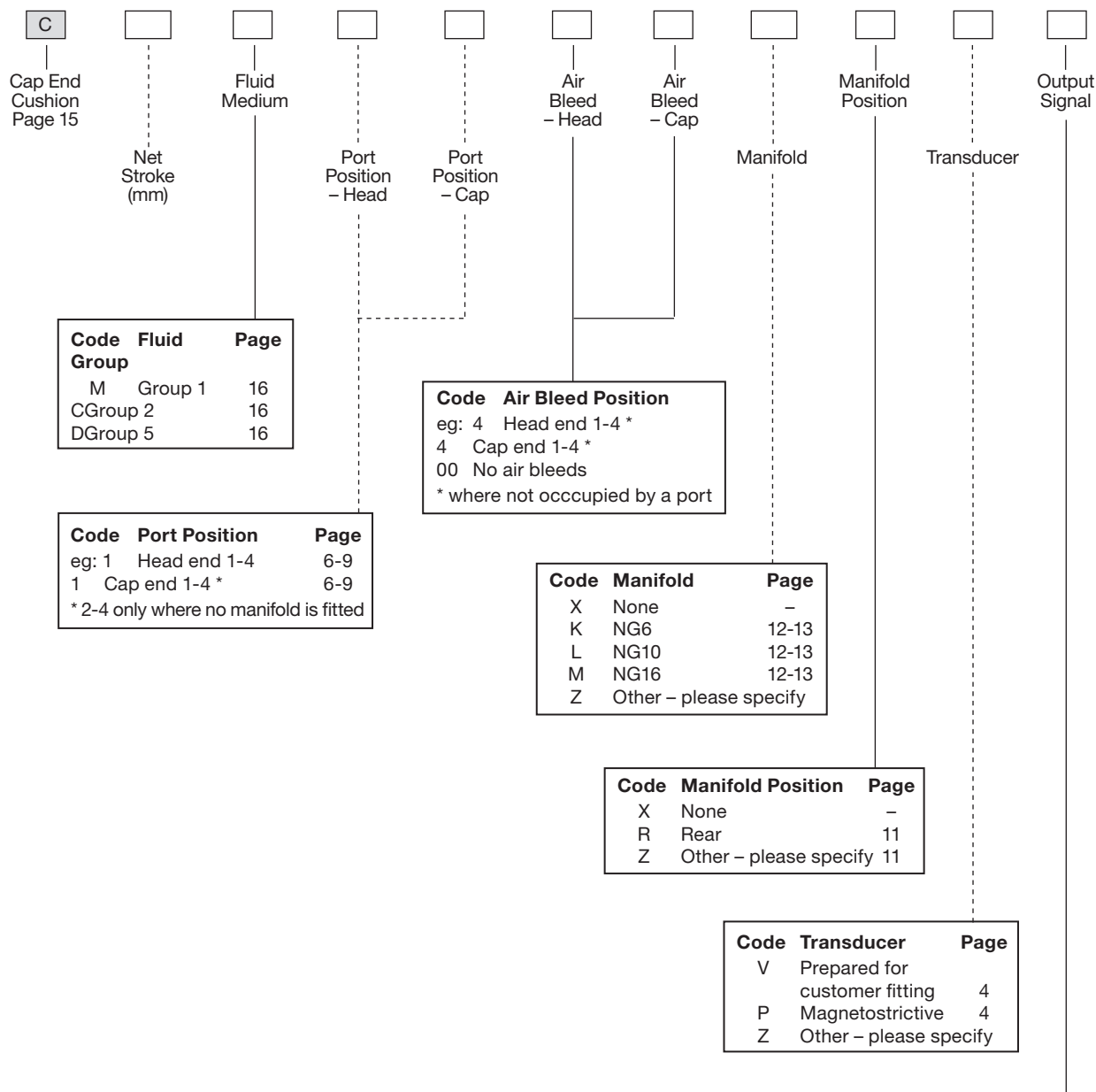

Port and Air Bleed Positions
 The positions of the ports and air bleed valves in the head and cap are selected by the position number (1 - 4) when viewed from the piston rod end.

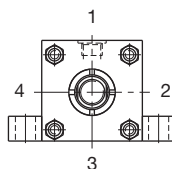

Code	Output Signal	Page
X	Not required	
A	0-10V	14
C	4-20mA	14
S	SSI - binary	14
T	SSI - gray	14
Z	Other - please specify	

Parker Worldwide

AE – UAE, Dubai

Tel: +971 4 8127100
parker.me@parker.com

AR – Argentina, Buenos Aires

Tel: +54 3327 44 4129

AT – Austria, Wiener Neustadt

Tel: +43 (0)2622 23501-0
parker.austria@parker.com

AT – Eastern Europe, Wiener Neustadt

Tel: +43 (0)2622 23501 900
parker.easteurope@parker.com

AU – Australia, Castle Hill

Tel: +61 (0)2-9634 7777

AZ – Azerbaijan, Baku

Tel: +994 50 2233 458
parker.azerbaijan@parker.com

BE/LU – Belgium, Nivelles

Tel: +32 (0)67 280 900
parker.belgium@parker.com

BR – Brazil, Cachoeirinha RS

Tel: +55 51 3470 9144

BY – Belarus, Minsk

Tel: +375 17 209 9399
parker.belarus@parker.com

CA – Canada, Milton, Ontario

Tel: +1 905 693 3000

CH – Switzerland, Etoy

Tel: +41 (0)21 821 87 00
parker.switzerland@parker.com

CL – Chile, Santiago

Tel: +56 2 623 1216

CN – China, Shanghai

Tel: +86 21 2899 5000

CZ – Czech Republic, Klecany

Tel: +420 284 083 111
parker.czechrepublic@parker.com

DE – Germany, Kaarst

Tel: +49 (0)2131 4016 0
parker.germany@parker.com

DK – Denmark, Ballerup

Tel: +45 43 56 04 00
parker.denmark@parker.com

ES – Spain, Madrid

Tel: +34 902 330 001
parker.spain@parker.com

FI – Finland, Vantaa

Tel: +358 (0)20 753 2500
parker.finland@parker.com

FR – France, Contamine s/Arve

Tel: +33 (0)4 50 25 80 25
parker.france@parker.com

GR – Greece, Athens

Tel: +30 210 933 6450
parker.greece@parker.com

HK – Hong Kong

Tel: +852 2428 8008

HU – Hungary, Budapest

Tel: +36 1 220 4155
parker.hungary@parker.com

IE – Ireland, Dublin

Tel: +353 (0)1 466 6370
parker.ireland@parker.com

IN – India, Mumbai

Tel: +91 22 6513 7081-85

IT – Italy, Corsico (MI)

Tel: +39 02 45 19 21
parker.italy@parker.com

JP – Japan, Fujisawa

Tel: +81 (0)4 6635 3050

KR – South Korea, Seoul

Tel: +82 2 559 0400

KZ – Kazakhstan, Almaty

Tel: +7 7272 505 800
parker.easteurope@parker.com

LV – Latvia, Riga

Tel: +371 6 745 2601
parker.latvia@parker.com

MX – Mexico, Apodaca

Tel: +52 81 8156 6000

MY – Malaysia, Shah Alam

Tel: +60 3 7849 0800

NL – The Netherlands, Oldenzaal

Tel: +31 (0)541 585 000
parker.nl@parker.com

NO – Norway, Asker

Tel: +47 66 75 34 00
parker.norway@parker.com

NZ – New Zealand, Mt Wellington

Tel: +64 9 574 1744

PL – Poland, Warsaw

Tel: +48 (0)22 573 24 00
parker.poland@parker.com

PT – Portugal, Leca da Palmeira

Tel: +351 22 999 7360
parker.portugal@parker.com

RO – Romania, Bucharest

Tel: +40 21 252 1382
parker.romania@parker.com

RU – Russia, Moscow

Tel: +7 495 645-2156
parker.russia@parker.com

SE – Sweden, Spånga

Tel: +46 (0)8 59 79 50 00
parker.sweden@parker.com

SG – Singapore

Tel: +65 6887 6300

SK – Slovakia, Banská Bystrica

Tel: +421 484 162 252
parker.slovakia@parker.com

SL – Slovenia, Novo Mesto

Tel: +386 7 337 6650
parker.slovenia@parker.com

TH – Thailand, Bangkok

Tel: +662 717 8140

TR – Turkey, Istanbul

Tel: +90 216 4997081
parker.turkey@parker.com

TW – Taiwan, Taipei

Tel: +886 2 2298 8987

UA – Ukraine, Kiev

Tel: +380 44 494 2731
parker.ukraine@parker.com

UK – United Kingdom, Warwick

Tel: +44 (0)1926 317 878
parker.uk@parker.com

US – USA, Cleveland (industrial)

Tel: +1 216 896 3000

US – USA, Lincolnshire (mobile)

Tel: +1 847 821 1500

VE – Venezuela, Caracas

Tel: +58 212 238 5422

ZA – South Africa, Kempton Park

Tel: +27 (0)11 961 0700
parker.southafrica@parker.com

European Product Information Centre

Free phone: 00 800 27 27 5374
(from AT, BE, CH, CZ, DE, EE, ES, FI, FR, IE, IL, IS, IT, LU, MT, NL, NO, PT, SE, SK, UK)

US Product Information Centre

Free phone: 1-800-27 27 537
www.parker.com

