

→ Series 682



■ MATERIAL



■ SPECIFICATION



DN 15 to DN 100 -20°C to +120°C

Inlet pressure:
up to 40 bar
Outlet pressure:
0,5 to 15 bar
depending on version

■ SUITABLE FOR

Liquids	neutral and non-neutral	
Air, gases and vapours	neutral and non-neutral	
Potable water cold	up to 40°C	
Potable water hot	up to 85°C	

■ EXAMPLES OF USE

For the protection of:

- domestic water supply systems
- commercial and industrial plants

against an excess supply pressure.

Pressure reducers are used, if within a piping system despite of varying pressures on the inlet side a certain pressure must not be exceeded on the outlet side.

- potable water supply according to DIN 1988
- process water supply in industrial- and building technology applications
- fire-fighting equipment and sprinkler systems
- shipbuilding industry and offshore plants

■ APPROVALS

DIN-DVGW type examination (up to 80°C)	
Type approval ACS	
Type approval WRAS (up to 85°C)	
TR ZU 032/2013 - TR ZU 010/2011	
Requirements	
DIN DVGW guidelines	DIN EN ISO 3822
DIN EN 1567	DGR 2014/68/EU
DIN 1988	
Classification society	
DNVGL	DNVGL
Lloyd's Register EMEA	LR EMEA
American Bureau of Shipping	ABS
Bureau Veritas	BV
Russian Maritime Register of Shipping	RMRS
Registro Italiano Navale	RINA

■ MATERIALS

Component	Material	DIN EN	ASME
Inlet body	Gunmetal	CC499K	CC499K
Outlet body	Gunmetal	CC499K	CC499K
Inner parts, wetted	Gunmetal	CC499K	CC499K
	Stainless Steel	1.4404	316 L
Spring	Spring steel with anti-rust protection	1.1200	ASTM A228
Strainer	Stainless Steel	1.4404	316 L

Series 682 ■ VALVE VERSION

m	with diaphragm	High-quality, heat-resistant moulded elastomere, fabric-reinforced diaphragm. Pressure adjustment by means of non-rising spindle. Valve insert with balanced single seat valve completely made of stainless steel.
k	with piston	Stainless steel piston (only for DN 100) Adjustment by means of non-rising spindle. Balanced single seat valve.
Complete valve cartridge SP/HP (order code: 482 Insert-DN..-seal) available as replacement part can be exchanged without removing the valve.		
Complete valve cartridge LP (order code: 482 LP Insert-DN..-seal) available as replacement part can be exchanged without removing the valve.		
Built-in dirt trap made of stainless steel.		
Mesh size:	DN 15 to DN 32 DN 40 to DN 100	0,60 mm 0,75 mm

■ MEDIUM

GF	gaseous and liquid	for water, neutral and non-sticking liquids, compressed air and neutral gases; optionally with FPM elastomere seals for non-neutral media i.e. oils, fuels, oil-laden compressed air, etc. Not suitable with steam.
-----------	--------------------	---------------------------------------------------------------------------------------------------------------------------------------------------------------------------------------------------------------------

■ TYPE OF LIFTING MECHANISM

0	without lifting device
----------	------------------------

■ OUTLET PRESSURE RANGES

SP	Standard version	Inlet pressure: up to 16 bar (PN 16) or 40 bar (PN 40)	Outlet pressure: from 1 to 8 bar
HP	High-pressure version (not for DN 65 and DN 80)	Inlet pressure: up to 16 bar (PN 16) or 40 bar (PN 40)	Outlet pressure: from 5 to 15 bar (5 to 13 bar, DN 100 with piston)
LP	Low-pressure version (not for DN 65, DN 80 and DN 100)	Inlet pressure: up to 16 bar (PN 16) or 25 bar (PN 40)	Outlet pressure: from 0,5 to 2 bar

■ AVAILABLE NOMINAL DIAMETERS AND CONNECTION SIZES

Nominal diameter DN	15	20	25	32	40	50	65	80	100
Inlet / Outlet	15/15	20/20	25/25	32/32	40/40	50/50	65/65	80/80	100/100
	■	■	■	■	■	■	■	■	■

■ TYPE OF CONNECTION INLET / OUTLET FLANGE CONNECTIONS

FL / FL	Standard	Flange connection / flange connection	DIN EN 1092 / DIN EN 1092
----------------	----------	---------------------------------------	---------------------------

■ SEALS

EPDM	Ethylene propylene diene	Elastomere moulded diaphragm and seals approvals according to drinking water directive	-20°C to +120°C (up to 8 bar outlet pressure) -20°C to +95°C (from 8 bar outlet pressure)
FKM	Fluorocarbon	Elastomere moulded diaphragm and seals	-10°C to +120°C (up to 8 bar outlet pressure) -10°C to +95°C (from 8 bar outlet pressure)

■ NOMINAL DIAMETERS, CONNECTIONS, INSTALLATION DIMENSIONS

Series 682: Connection, installation dimensions, ranges of adjustment											
Connection		DN15	DN20	DN25	DN32	DN40	DN50	DN65	DN65	DN80	DN100
		PN16 / PN40	PN16 / PN40	PN16 / PN40	PN16 / PN40	PN16 / PN40	PN16 / PN40	PN16	PN40	PN16 / PN40	PN16
Inlet pressure SP, HP up to	bar	16 / 40	16 / 40	16 / 40	16 / 40	16 / 40	16 / 40	16	40	16 / 40	16
Inlet pressure LP up to	bar	16 / 25	16 / 25	16 / 25	16 / 25	16 / 25	16 / 25				
Outlet pressure	bar	0,5 – 2	0,5 – 2	0,5 – 2	0,5 – 2	0,5 – 2	0,5 – 2	1 – 8	1 – 8	1 – 8	1 – 8 5 – 13
		1 – 8	1 – 8	1 – 8	1 – 8	1 – 8					
		5 – 15	5 – 15	5 – 15	5 – 15	5 – 15					
Installation dimensions in mm	D	95	105	115	140	150	165	185	185	200	220
	L	130	150	160	180	200	230	290	290	310	350
	H (H1)	102 (128 ¹)	130 (150 ¹)	130 (150 ¹)	130 (150 ¹)	165 (185 ¹)	165 (185 ¹)	235	235	235	320 (340 ³)
	H2 (H3)	124 (150 ²)	161 (181 ²)	161 (181 ²)	161 (181 ²)	198 (218 ²)	198 (218 ²)				
	h	46	50	55	68	73	80	89	89	96	112
	K / nxd	65 / 4xM12	75 / 4xM12	85 / 4xM12	100 / 4xM16	110 / 4xM16	125 / 4xM16	145 / 4xM16	145 / 8xM16	160 / 8xM16	180 / 8xM16
Pressure gauge connections	G1							1/4" radial	1/4" radial	1/4" radial	1/4" axial
Inlet pressure											
Pressure gauge connections	G1	1/4" axial	1/4" axial	1/4" axial	1/4" axial	1/4" axial	1/4" axial	1/4" radial	1/4" radial	1/4" radial	1/4" axial
Outlet pressure											
Weight	kg	2,8 (3,1 ¹)	4,2 (4,6 ¹)	4,7 (5,1 ¹)	5,9 (6,3 ¹)	8,6 (9,3 ¹)	10,5 (11,2 ¹)	20	20	22	40 (43 ³)
Coefficient of flow K_{vs} ⁴	m ³ /h	3	5,8	6,7	7,6	12,5	15	25	25	26	80

¹for type 682mGFO-LP

²for type 682mGFO-LP S15

³for type 682kGFO-HP

⁴The K_{vs} value was determined according to DIN EN 60534-2-3. Instructions on how to determine size and capacity are to be found under section 2.

■ MAIN DIMENSIONS, INSTALLATION DIMENSIONS

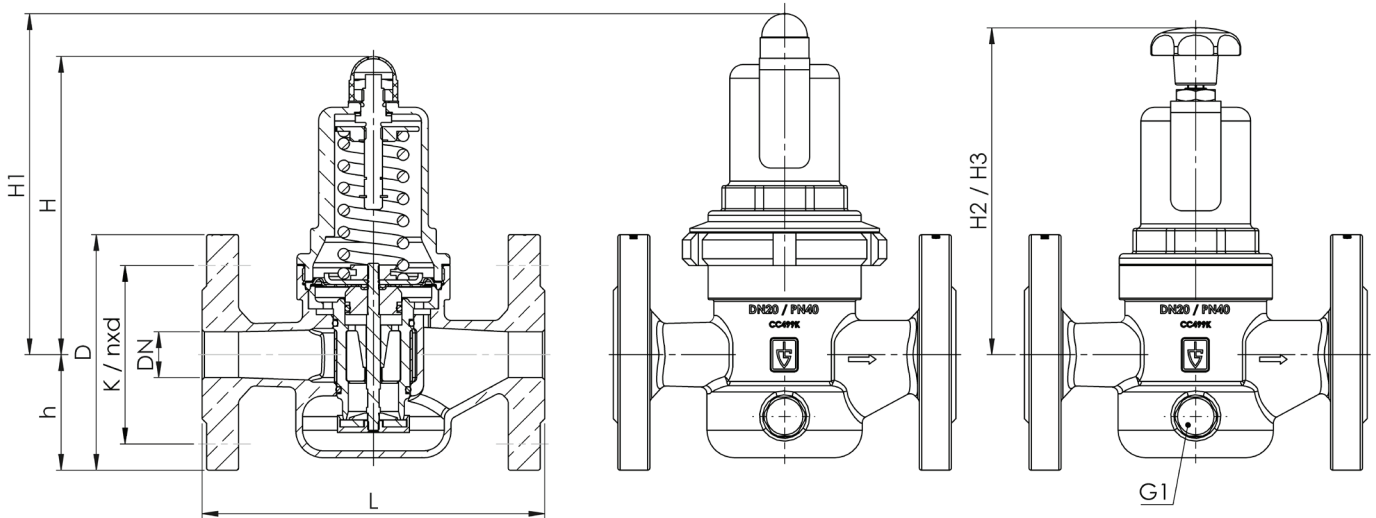

Series	Valve version	Medium	Lifting device	Outlet pressure	Nominal diameter DN	Connection type		Connection size		Seal	Options	Optional: fixed setting	Quantity
						Inlet	Outlet	Inlet	Outlet				
682	m	GF	0	HP	50	FL	FL	50	50	EPDM			5
682	k	GF	0	SP	100	FL	FL	100	100	FKM	S71	7	2
682		GF	0			FL	FL						
682		GF	0			FL	FL						

■ PROPERTIES

S15	Hand wheel (plastic) for tool-free setting of setpressure ¹	<input type="checkbox"/>		<input type="checkbox"/>
S17	Supply with manometers suitable for the valve finish	<input type="checkbox"/>		<input type="checkbox"/>
S71	Preliminary setup for protection against manipulation of the preset pressure (seal)	<input type="checkbox"/>		<input type="checkbox"/>

¹For nominal diameters DN15 to DN50 outlet pressure ranges LP and SP

■ OPTIONS

GOX	Especially for gaseous O2 applications by employment of specific materials including oil- and grease free production process	<input type="checkbox"/>	P03	Galvanically nickel-plated finish	<input type="checkbox"/>
P01	Oil- and grease-free production	<input type="checkbox"/>	FE	Setting and sealing	<input type="checkbox"/>
P02	Chemically nickel-plated finish	<input type="checkbox"/>			<input type="checkbox"/>

■ CERTIFICATES / APPROVALS

C01	Factory certificate acc. DIN EN 10204 2.2 (WKZ 2.2)	<input type="checkbox"/>	C05	Sealing material Manufacturer certification (FDA, USP 3, 3-A,...), Please indicate description of certificate:	<input type="checkbox"/>
C02	Test certificate acc. DIN EN 10204 3.1 (WPZ 3.1)	<input type="checkbox"/>	C06	ATEX evaluation acc. to 2014/34/EU	<input type="checkbox"/>
C03	Material test certificate acc. DIN EN 10204 3.1 (MPZ 3.1) (pressure retaining part)	<input type="checkbox"/>	C10	Certificate of oil- and grease free production	<input type="checkbox"/>
C04	TÜV/DEKRA individual inspection acc. EN 10204 3.2 (TÜV/DEKRA-APZ)	<input type="checkbox"/>	C11	Certification of the production process especially for gaseous oxygen applications by employment of specific materials	<input type="checkbox"/>

■ ADMISSIONS / ACCREDITATIONS

AA1	EC Type examination acc. to Directive 2014/68/EU	<input checked="" type="checkbox"/>	AK1	DNV-GL (DNVGL) type approval	<input type="checkbox"/>
AA4	EAC - certificate/declaration with passport for the valve and laser marking of the valve	<input type="checkbox"/>	AK2	Lloyd's Register (LR) type approval	<input type="checkbox"/>
AB1	Deutscher Verein des Gas- und Wasserfaches, DVGW type approval	<input type="checkbox"/>	AK3	American Bureau of Shipping (ABS) type approval	<input type="checkbox"/>
AB2	Water regulations and advisory scheme WRAS type approval	<input type="checkbox"/>	AK4	Bureau Veritas (BV) type approval	<input type="checkbox"/>
AB3	Attestation de Conformité Sanitaire, ACS type approval	<input type="checkbox"/>	AK5	Russian Maritime Register of Shipping (RMRS) type approval	<input type="checkbox"/>
		<input type="checkbox"/>	AK6	Registro Italiano Navale (RINA) type approval	<input type="checkbox"/>
		<input type="checkbox"/>	AL	Individual inspection by notified body inspector – (body to be indicated):	<input type="checkbox"/>

■ ENQUIRY

Copy and send to: order@goetze-armaturen.de.

Order form easily to be found online under the section for each series.

Series 682:

Dimensioning by pressure loss on the outlet pressure side

Flow chart water

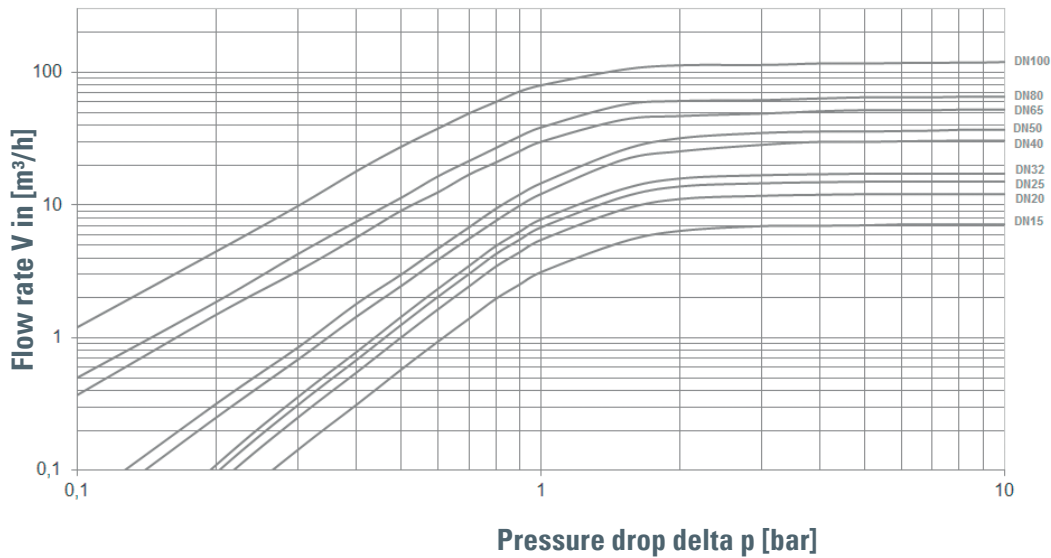

Dimensioning by flow velocity

For liquids:

With help of the chart you can determine the nominal diameter (DN) for a given flow volume V (m³/h). According to DVGW-guidelines (DIN 1988) a flow velocity of 2 m/s in domestic water supply systems should not be exceeded.

For compressed air and other gaseous media:

The usual flow velocity for compressed air is 10 - 20 m/s. For gaseous media the flow volume V should always be shown in actual cubic meters/hour. If the flow volume is given in standard cubic meters, these should be converted into actual cubic meters before using the diagram.

$$V(\text{m}^3/\text{h}) = \frac{V_{\text{Norm}} (\text{Nm}^3/\text{h})}{p_{\text{absolut}} (\text{bar})} = \frac{V_{\text{Norm}}}{p_{\text{U}} + 1}$$

Actual cubic meters are based on the prevailing pressure of the medium on the outlet side of the pressure reducer.

